



AWESOME METAL
Special



1 Suspension



page 3

2 Brake & Wheel



page 23

3 Engine



page 36

4 Cutting Tools



page 39

5 Auto Body / Consumables



page 40

6 Universal Tools



page 50

7 Power Tools



page 55

8 Equipment



page 57

9 Merchandising



page 58

HIGH PERFORMANCE AIR HAMMER "VIBRO-IMPACT" SYSTEM

Suspension



EQ-290 206



WATCH DEMO HERE:



290 210



290 220



290 230



290 241



"VIBRO-IMPACT" System-tool to loosen tight connections. The high performance air hammer helps to disassemble e. g. conical seat connections, wheel bearings, bushes, rusted screw connections.

EQ-290 206 High Performance Air Hammer "VIBRO-IMPACT" System

TWIN-CONE WHEEL BEARING KIT

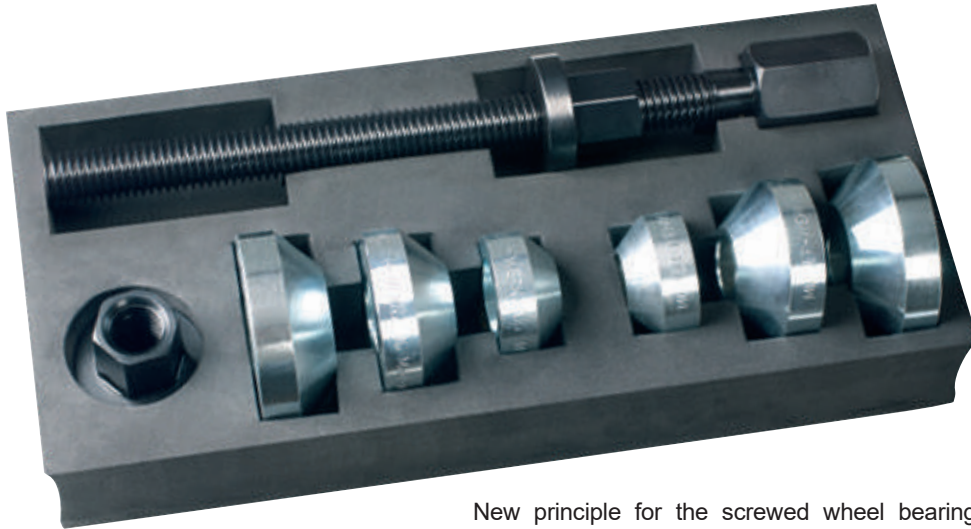

WATCH DEMO HERE:



New principle for the screwed wheel bearings. Fits the majority of other wheel bearings as well. Makes a solid connection, so it is easier to remove when using slide hammer.

432 005 Twin-cone wheel bearing kit

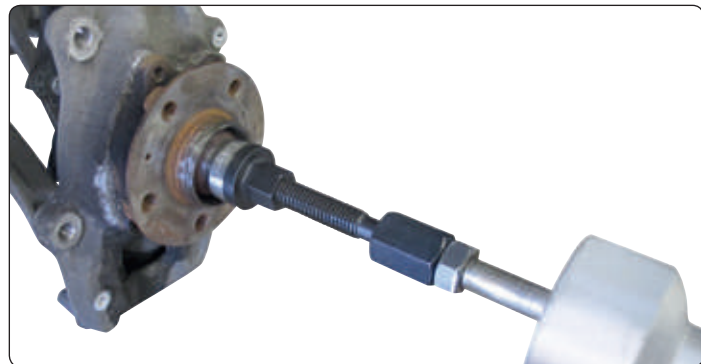
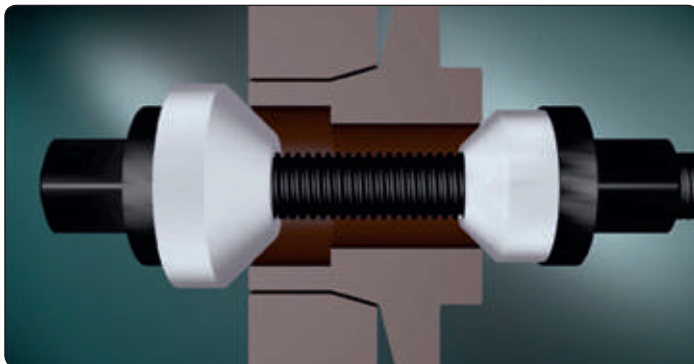
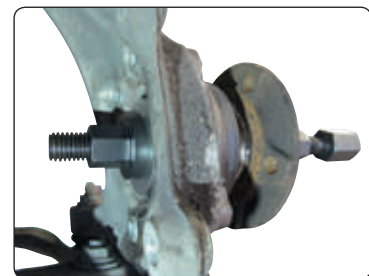

UNI WHEEL BEARING KIT



Suitable for almost all vehicles **with bearing hub units (compact bearings)** as well as, vehicles with **conventional wheel bearings**.

Can assemble or disassemble.

Can also be used for with hydraulic hollow piston cylinders or under the workshop press.

This kit comes in a sturdy case and includes a "Vibro-Impact" spindle. Parts available separately. Made in Germany.

432 030 Uni wheel bearing kit

UNIVERSAL PRESS DISC KIT

Reducing rings Ø:
80, 100, 120 mm

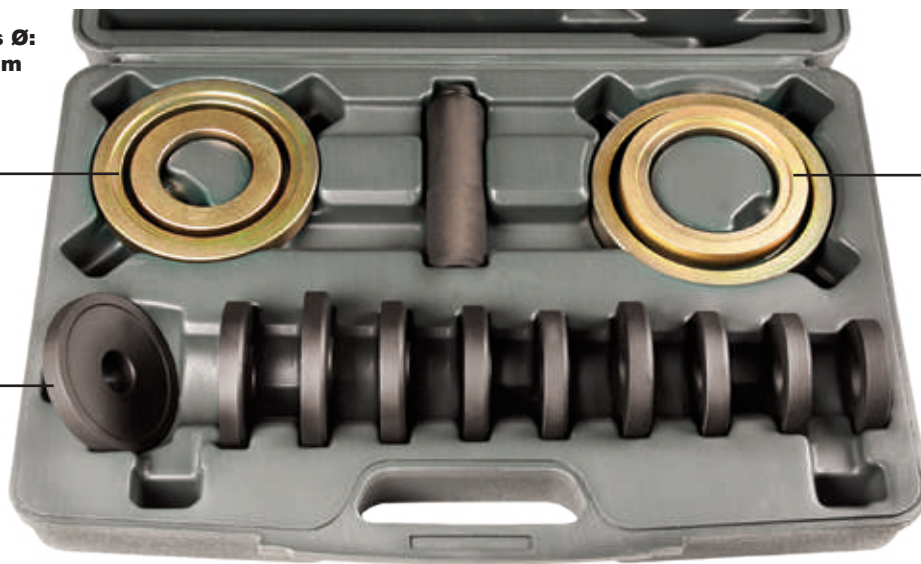

Receiving ring
e.g. for axle stubs Ø:
OD 130 x ID 110 mm

Press discs Ø:
60, 65, 68, 70, 72, 74, 77, 80, 82, 85 mm

Universal tool set for pressing in or out wheel bearings, bushings, shaft seals etc.
Kit consists of 10 press discs, 3 reducing rings, 1 receiving ring, and 1 driver.
Supplied in a quality storage case.

432 600 Universal Press Disc Kit

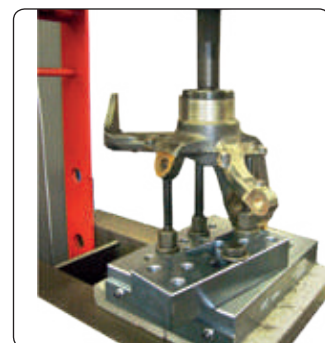
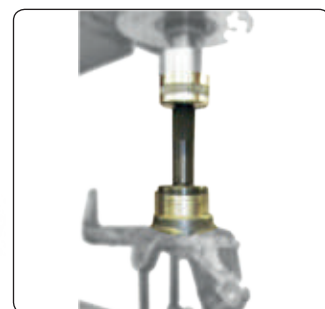

UNIVERSAL PRESS RING

To be used in conjunction with the Universal Press Plate #432 650. This tool will help you press out wheel bearings by holding the hubs.

A large diameter ring (179 mm) sits across the press plate allowing large hubs to be placed on the ring.

Great alternative to V blocks and having to stack multiple items to create an unstable support for your press.



432 711 Universal Press Ring

UNIVERSAL PRESS SUPPORT



WATCH DEMO HERE:

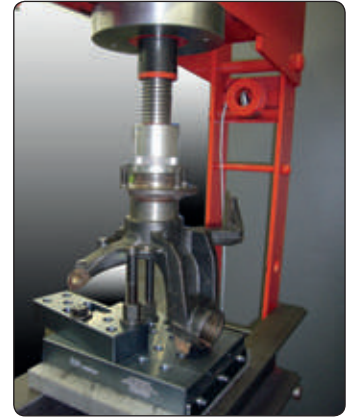

Makes the shop press safe and easy to use.

Creates three points of contact for stability and is infinitely adjustable to fit irregularly shaped objects.

Includes:

- 3 Pressure distribution washers
- 3 High pressure nuts
- 2 Medium high strength studs
- 2 Long high strength studs
- 1 Short high strength stud
- Swivel lock
- Base with innovative numbering system for easy use

432 650 Universal Press Support

SUSPENSION WEAR INDICATOR



Strut Bushing and Bearings

Link Pin Bushings

Wheel Bearing and CV Axle Play

Ball Joints

Tie Rod Ends and Rack Mounts

Torsion Bar Bushings
Control Arm Bushings

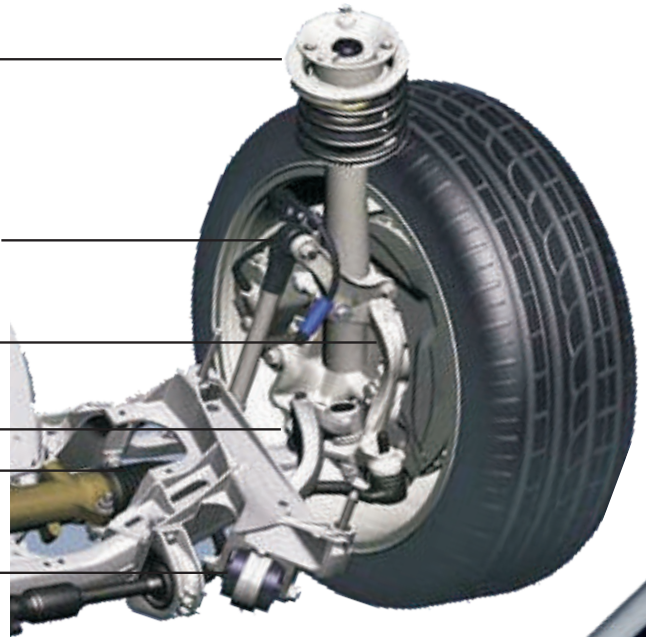

This innovative tool effectively helps identify all kinds of worn suspension components

Allows user to positively SEE, FEEL and HEAR problem areas while performing diagnostics.

432 910

Suspension Wear Indicator

U.S. Patent pending



WATCH DEMO HERE:

SUSPENSION KIT

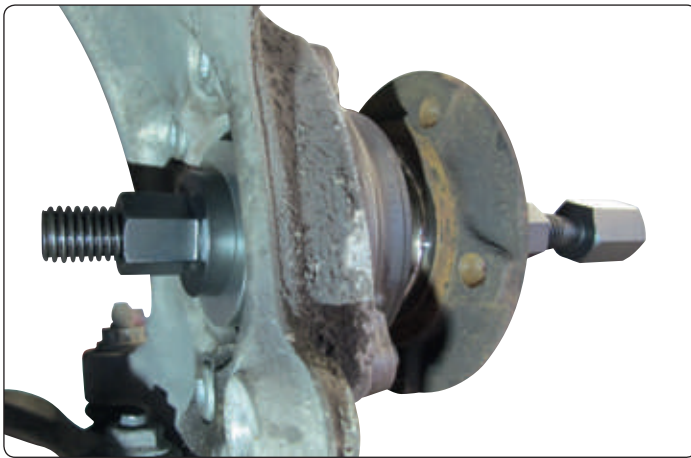
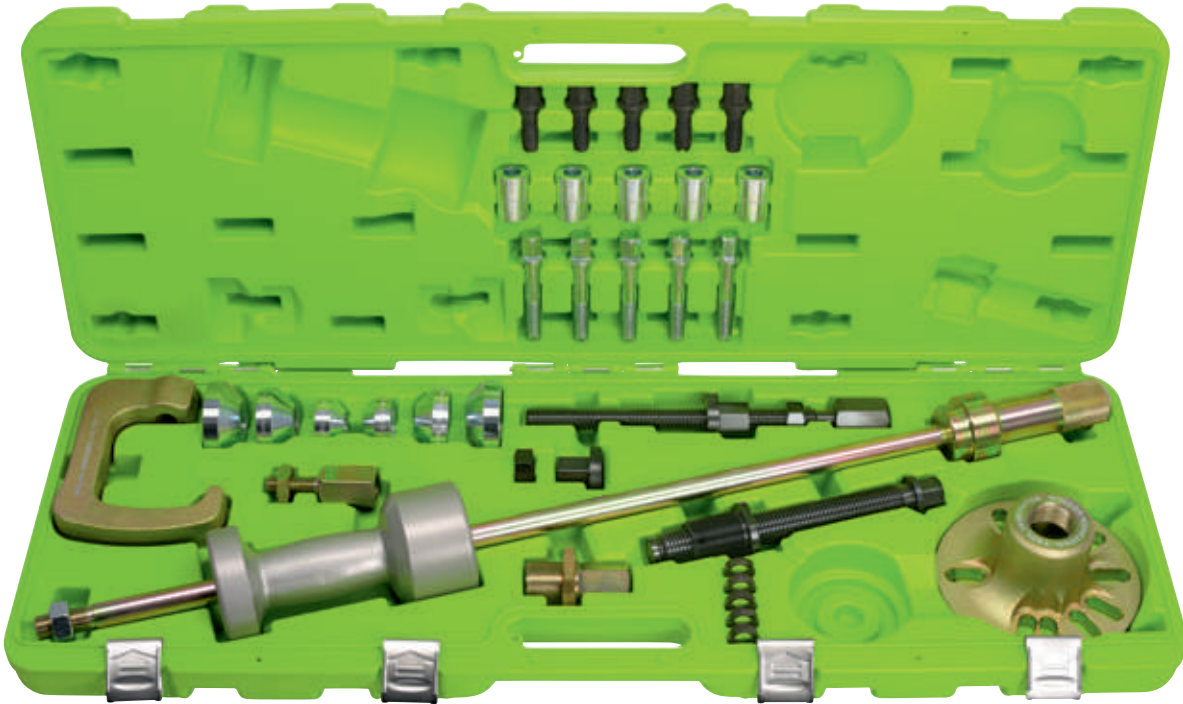

The master suspension kit can help you remove all components of the wheel knuckle. From the wheel bearing assembly, to the drive shaft push out and even lower ball joint/suspension arm removal.

The kit includes:

- XL slide hammer
- Drop forged flange
- Drop forged hook
- Twin cone set with a **"VIBRO-IMPACT"** spindle
- Adaptor to use your existing tools with the XL slide hammer.

All components are neatly stored in our signature neon green carrying case.

433 100 Suspension kit

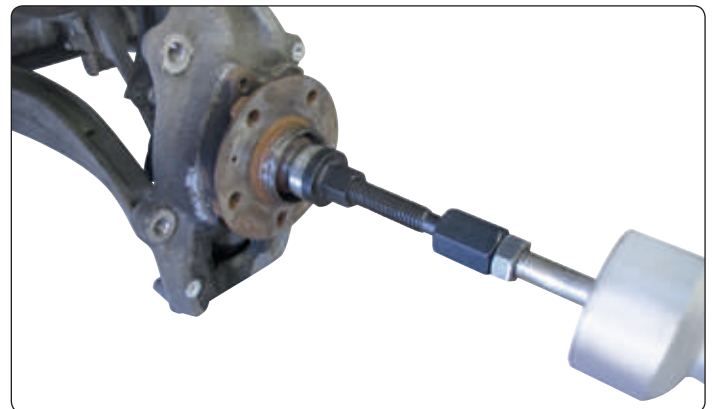
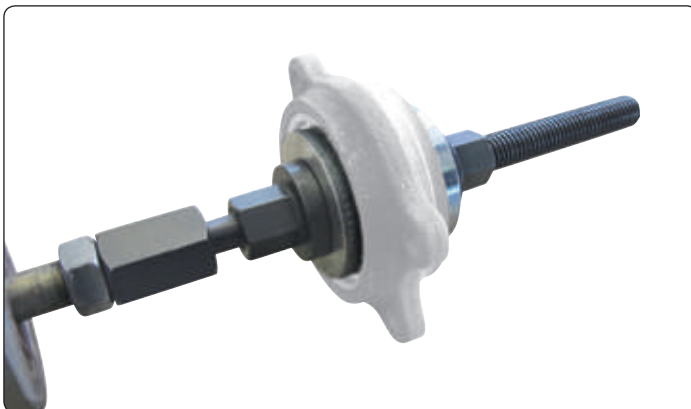

UNI DRIVE SHAFT PUSHER / HUB PULLER

Universal tool for pushing out bonded (microencapsulated) or heavily corroded drive shafts. Damage to the drive shaft thread is prevented. Suitable for almost all 4- and 5-hole wheel hubs with a pitch circle diameter up to 136 mm.

The "VIBRO-IMPACT" principle: the vibration impact of the pneumatic wrench is transmitted to the wheel hub and to the drive shaft through the trapezoidal thread spindle.

When used in conjunction with the slide hammer 433 450, the drop-forged flange can also be used for extracting wheel hubs.

**# 433 414 UNI Drive shaft pusher / Hub puller *
Original "VIBRO-IMPACT"**

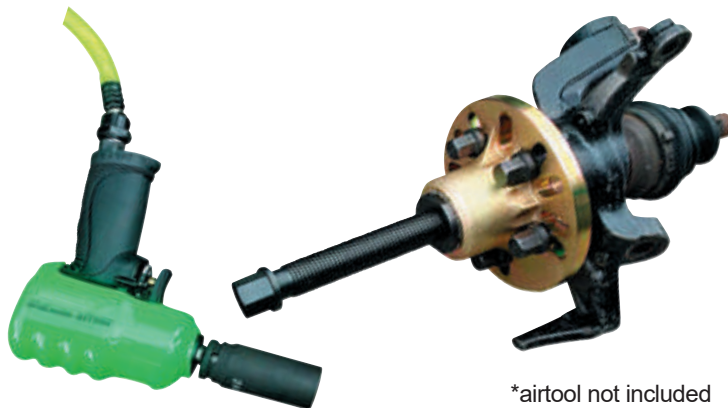

*airtool not included



XL WHEEL HUB SLIDE HAMMER

Kit contains:

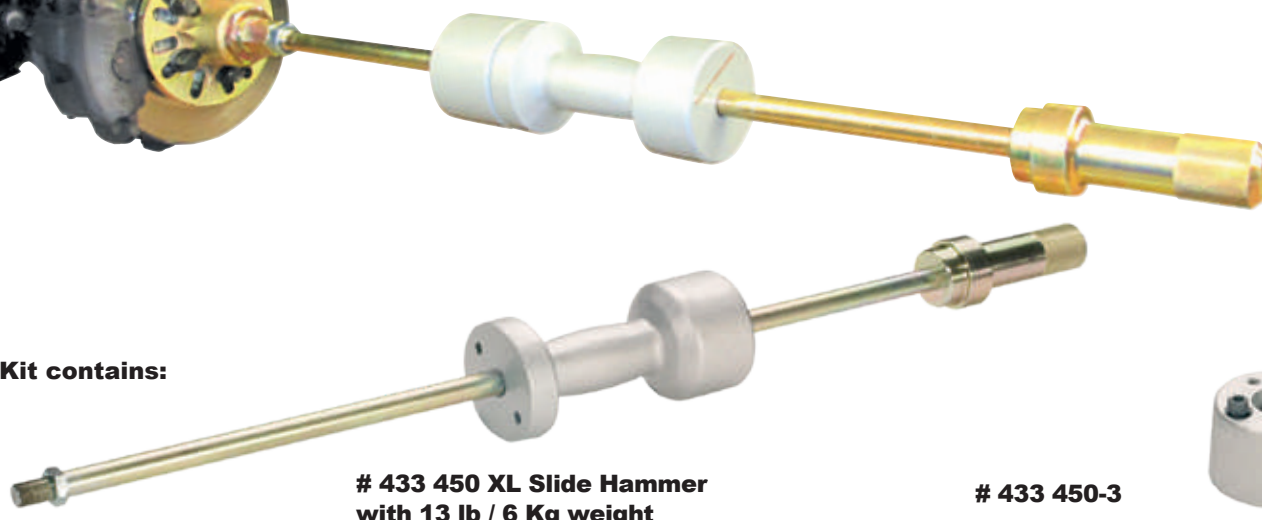

**# 433 450 XL Slide Hammer
with 13 lb / 6 Kg weight**

433 450-3

**Optional 6.6 lb / 3 kg add on weight
for additional power.**



**# 433 450/14
Adapter UN 1 1/2"**



**# 433 433
Wheel Hub Basic Unit**

Suitable for 4 and 5 lug applications. Drop forged for exceptional strength.

Provides up to 11 tons of pulling power for quick disassembly of even the toughest jobs.

433 437 XL Wheel Hub Slide Hammer

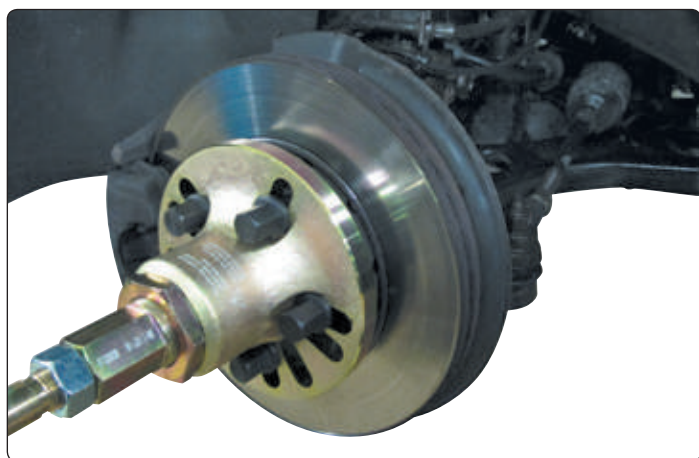

TIE ROD WRENCH

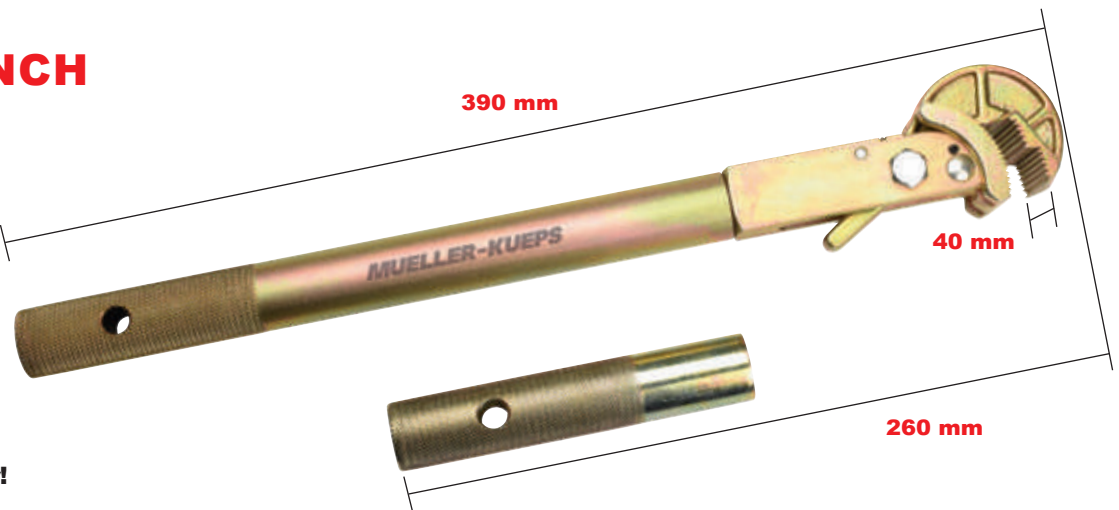

Inner tie rod multi grip plier!

Alignment problems due to rusty and stocked inner tie rod adjustments? This plier has the grip you need on any round or hex surface of the rod. Includes two lengths of levers, one for maximum power and one for narrow spaces.

Grip width: 40 mm
Grip diameter: 14 - 23 mm
Lever length: 260 - 390 mm

512 002 Tie Rod Wrench

UNI-EXTENDER

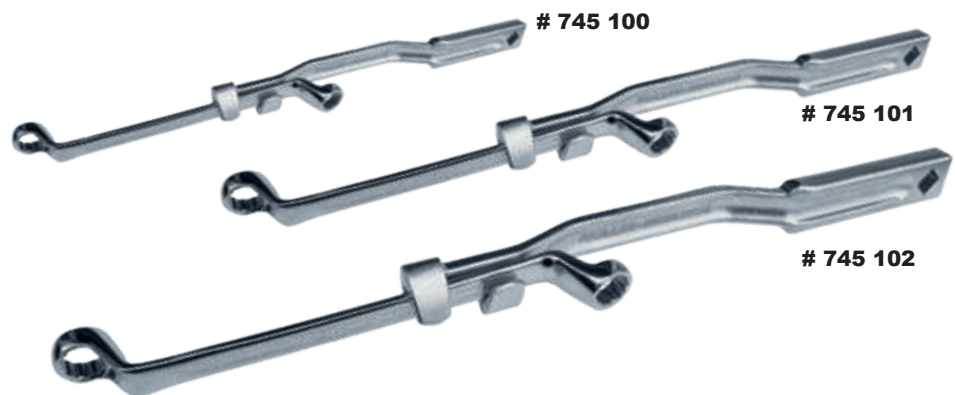

Uni-extender to loosen tight connection in hard to reach areas.

- Fits wrenches perfectly
- To loosen tight connection of hex, TX and XZN
- Reduces risk of injuries.

745 100 **Uni-Extender**
length: 340 mm; max. SW26 / 26 mm

745 101 **Uni-Extender Type 1**
length: 450mm; max. SW32 / 32 mm

745 102 **Uni-Extender Type 2**
length: 580 mm; max. SW46 / 46 mm

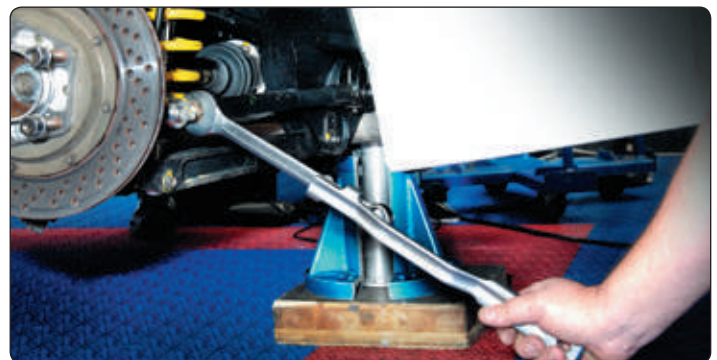

PINCH BOLT REMOVAL KIT



603 336-1
Drill-sleeve



603 336-5
HSSE-TICN Special drill



603 336-4
HSSE-TIN
Special drill, 7,3mm



603 334-3
Pin, 9,8x63mm



290 214
Pin punch 6,5mm
for air hammer

For the removal of the aluminum 4-link locking bolt via the exact central drilling method. Remove rusted and corroded bolts easily with this 3-step kit. By pushing the bolt out with the pin, the end of the screw thread cannot be widened. Use with the # 290 206 High Performance Air Hammer for best results.

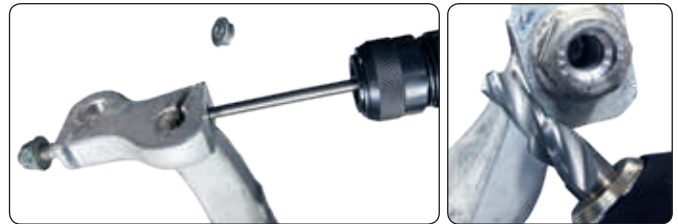

603 336 Pinch Bolt Removal Kit

EXCENTRIC TURN CHUCK



Completely Drop-Forged

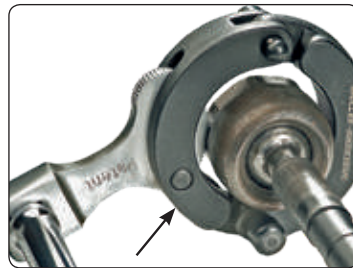

Maximum Grip



Opens both ways

1/2" Drive for Maximum Power when used with:

- Extra Long Extension
- Breaker Bar
- Ratchet

PROFESSIONAL DISTRIBUTOR
Most Wanted

Special tool for servicing and adjusting tie rod ends.

Tool opens both ways to allow universal usage for easy tie rod replacement or wheel alignment.

608 950 Exentric Turn Chuck
U.S. Patent



WATCH DEMO HERE:

BALL JOINT SEPARATOR KIT



WATCH DEMO HERE:



"VIBRO-IMPACT" spindle

Designed to be used with an Impact tool



Fast and safe removal of suspension and steering system ball joints.



All Forks separately available:

Size	no.
24mm	609 033-24
27mm	609 033-27
31mm	609 033-31

optional:

36mm	609 033-36
------	------------

609 033/5

- The Ball Joint Separator has a very rugged and flat design, with 3 interchangeable forks. These are attached to the center screw to allow continuous adjustment within the jaw capacity range.
- Completely drop forged.
- Jaw capacity range from 30 – 65 mm
- 3 different fork sizes (24, 27 and 31 mm) makes this a very adaptable separator.
- e.g. Audi / VW (A3, A4 and A6 with double wishbone), BMW, Mercedes-Benz.
- Comes with "Vibro-Impact" reaction screw. Making your work quick and safe.
- Will not damage aluminum parts and rubber components.
- Always keep the forks parallel to each other when tool is in use.

609 033 **Ball Joint Separator Kit**

609 033/5 **Ball Joint Separator Kit**
incl. Wall Mount



VIBRO-IMPACT® BELL SHAPE SEPARATOR



609 039
e.g. DB 1424



609 039
e.g. DB Actros 2



609 035
e.g. DB Sprinter / VW LT



Due to the "Vibro-Impact" principle you can now remove suspension joints with your Impact. Reduce the force needed to prevent damage. This drop-forged tool makes removing the suspension fast and easy.

609 035 Bell shape separator 35mm

609 039 Bell shape separator 39mm

Combination tools for dismantling and installing the suspension joints on a VW LT/DB Sprinter directly on the vehicle.

609 147/V2 Pressure piece kit LT/Sprinter

609 312 Universal Base frame incl. 12 ton hydraulic spindle



609 147/V2



609 312

XS PRESS AND PULL SLEEVE KIT



**THE #1 MANUFACTURER
IN THE WORLD OF PRESS AND
PULL SLEEVE KITS!!**



WATCH DEMO HERE:



609 390

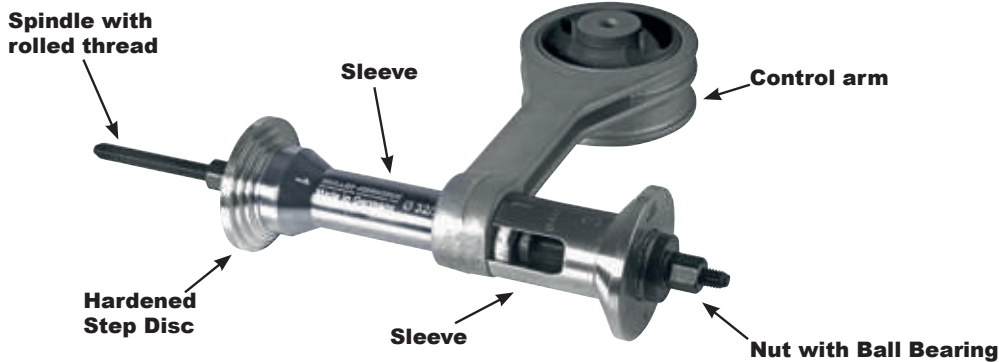

Sleeves can be stacked
with # 609 400 sleeves

Sleeves outer diameter from:

24 - 42 mm
15/16" - 1-21/32"

Universal tool set for extracting and mounting: silent bearings, hydraulic bearings, ball bearings, rubber bearings, shaft seals, bearing bushings, etc.

Universal application makes it ideal for various vehicles, especially newer cars with smaller bearings.

609 390/Basic is ideal to use in combination with the # 609 400 Press and Pull Kit.

609 390 XS Press and Pull Sleeve Kit
(10 sleeves, 3 spindles, 4 discs)

609 390/Basic XS Press and Pull Sleeve Kit Basic
U.S. Patent pending (10 sleeves, 1 spindle)



609 390/Basic

PRESS AND PULL SLEEVE KIT



WATCH DEMO HERE:

PROFESSIONAL DISTRIBUTOR
 Most Wanted

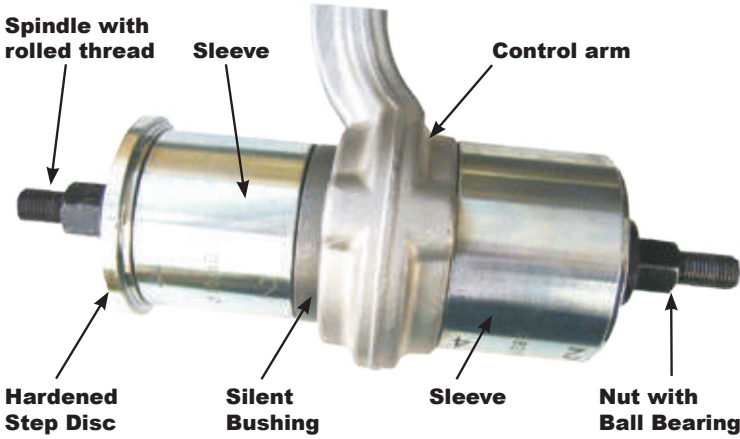

Sleeves outer diameter from:
 44 - 82 mm
 1-3/4" - 3-1/8"



Universal tool set for extracting and mounting: silent bearings, hydraulic bearings, ball bearings, rubber bearings, shaft seals, bearing bushings, etc.
 Ideal for various vehicles due to its universal application.

609 399
 U.S. Patent pending

609 399/Upgrade

609 400
 U.S. Patent pending

Press and Pull Sleeve Kit Basic
 (8 sleeves, 2 spindles, 4 discs)

Press and Pull Sleeve Kit Upgrade
 (12 sleeves, 2 spindles)

Press and Pull Sleeve Kit
 (20 sleeves, 4 spindles, 4 discs)



PRESS AND PULL SLEEVE COMBINATION KIT



WATCH DEMO HERE:



The #1 Press & Pull kit on the market!

- Our complete package! 20 Sleeves / 4 Discs!
- Sleeves can be stacked.
- Sleeves outer diameter range: 1-3/4" – 3-1/8"
- Including XL C-Clamp
- Includes "Vibro-Impact" Tool, allowing the use of an impact wrench
- Comes in our signature neon green carrying case.

Applications:

Remove/Install:

- Silent Bearings
- Hydraulic Bearings
- Ball Bearings
- Shaft Seals/Bearing Bushings
- Rubber Bearings
- Etc.

609 400/460

**Press and Pull Sleeve
Combination Kit**



UNIVERSAL PRESS AND PULL SLEEVE KIT TYPE II



609 420



Sleeves outer diameter from:
84 - 122 mm
3 -11/32" - 4-13/16"



609 420/Basic



- Universal tool set for removing and installing all types of bushings, bearings and seals.
- Includes sleeves that are large enough to fit most heavy duty applications.

609 420

U.S. Patent pending

609 420/Basic

Universal Press and Pull Sleeve Kit Type II (20 Sleeves, 6 Spindles, 4 discs)

Universal Press and Pull Sleeve Kit Type II Basic

(8 Sleeves, 3 spindles, 4 discs)



WATCH DEMO HERE:



C-CLAMP AND BASE FRAME KIT

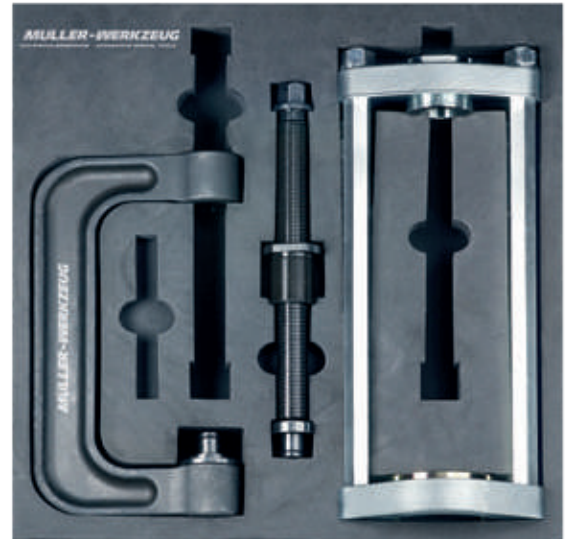

A supplementary tool for # 609 390, # 609 399 and the # 609 400, Universal Press Pull Sleeve Kit.

Specifically made for use with **impact tools** to increase power and speed.

609 465 **Combo with # 609 315 + # 609 460 in foam inlay**

609 460 **C-Clamp with Impact Spindle**



XL PRESS FRAME

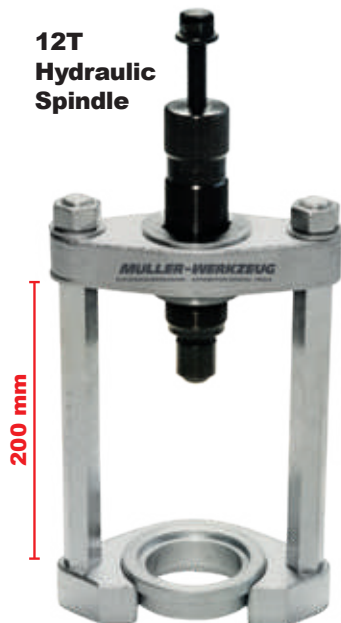

609 312 **Press Frame with 12T Hydraulic Spindle (200 mm) long**



609 315 **XL Press Frame without Spindle**

A supplementary tool for # 609 460, XL C-Clamp and # 609 390, # 609 399 and # 609 400, Universal Press Pull Sleeve Kit.

Specifically made to increase power and speed.



609 316 **XL Press Frame with Impact Spindle (350 mm) long**

CONTENTS FOR PRESS AND PULL SLEEVE KIT

Art.-no.	609 420	609 400/460	609 400	609 399	609 390 XS	609 390/Basic XS	609 390/10 XS	
609 390-1					x	x		Blow case for 609 390
609 390-14/24					x	x	x	XS-Sleeve I: 14 A: 24
609 390-16/26					x	x	x	XS-Sleeve I: 16 A: 26
609 390-18/28					x	x	x	XS-Sleeve I: 18 A: 28
609 390-20/30					x	x	x	XS-Sleeve I: 20 A: 30
609 390-22/32					x	x	x	XS-Sleeve I: 22 A: 32
609 390-24/34					x	x	x	XS-Sleeve I: 24 A: 34
609 390-26/36					x	x	x	XS-Sleeve I: 26 A: 36
609 390-28/38					x	x	x	XS-Sleeve I: 28 A: 38
609 390-30/40					x	x	x	XS-Sleeve I: 30 A: 40
609 390-32/42					x	x	x	XS-Sleeve I: 32 A: 42
609 400		x	x					Pressing + Pulling Tube Kit
609 400-34/44		x	x	x				Press-Pull Sleeve I: 34 mm A: 44 mm
609 400-36/46		x	x					Press-Pull Sleeve I: 36 mm A: 46 mm
609 400-38/48		x	x					Press-Pull Sleeve I: 38 mm A: 48 mm
609 400-40/50		x	x					Press-Pull Sleeve I: 40 mm A: 50 mm
609 400-42/52		x	x	x				Press-Pull Sleeve I: 42 mm A: 52 mm
609 400-44/54		x	x	x				Press-Pull Sleeve I: 44 mm A: 54 mm
609 400-46/56		x	x	x				Press-Pull Sleeve I: 46 mm A: 56 mm
609 400-48/58		x	x					Press-Pull Sleeve I: 48 mm A: 58 mm
609 400-50/60		x	x					Press-Pull Sleeve I: 50 mm A: 60 mm
609 400-52/62		x	x	x				Press-Pull Sleeve I: 52 mm A: 62 mm
609 400-54/64		x	x					Press-Pull Sleeve I: 54 mm A: 64 mm
609 400-56/66		x	x					Press-Pull Sleeve I: 56 mm A: 66 mm
609 400-58/68		x	x					Press-Pull Sleeve I: 58 mm A: 68 mm
609 400-60/70		x	x					Press-Pull Sleeve I: 60 mm A: 70 mm
609 400-62/72		x	x					Press-Pull Sleeve I: 62 mm A: 72 mm
609 400-64/74		x	x	x				Press-Pull Sleeve I: 64 mm A: 74 mm
609 400-66/76		x	x					Press-Pull Sleeve I: 66 mm A: 76 mm
609 400-68/78		x	x					Press-Pull Sleeve I: 68 mm A: 78 mm
609 400-70/80		x	x	x				Press-Pull Sleeve I: 70 mm A: 80 mm
609 400-72/82		x	x	x				Press-Pull Sleeve I: 72 mm A: 82 mm
609 400/D10	2x	2x	2x		2x			Nut M10 with Bearing
609 400/D12	2x	2x	2x	2x	2x			Nut M12 with Bearing
609 400/D14	2x	2x	2x					Nut M14 with Bearing
609 400/D16		2x	2x	2x				Nut M16 with Bearing
609 400/K				x				Blow Case for 609 400
609 400/P1		x	x	x	x			Step Disc No. 1 Size: 34, 42, 50, 58, 66
609 400/P2		x	x	x	x			Step Disc No. 2 Size: 36, 44, 52, 60, 68
609 400/P3		x	x	x	x			Step Disc No. 3 Size: 38, 46, 54, 62, 70
609 400/P4		x	x	x	x			Step Disc No. 4 Size: 40, 48, 56, 64, 72
609 400/S10	x	x	x		x			Spindle M10 without Nut
609 400/S12	x	x	x	x	x			Spindle M12 without Nut
609 400/S14	x	x	x					Spindle M14 without Nut
609 400/S16	x	x	x	x				Spindle M16 without Nut
609 400/460-C		x						Blow case for 609 400/460

Art.-no.	609 420	609 400/460	609 400	609 399	609 390 XS	609 390/Basic XS	609 390/10 XS	
609 420								Pressing + Pulling Tube Kit II
609 420-1	x							Blow Case for 609 420
609 420-100/110	x							Press-Pull Sleeve I: 100 mm A: 110 mm
609 420-102/112	x							Press-Pull Sleeve I: 102 mm A: 112 mm
609 420-104/114	x							Press-Pull Sleeve I: 104 mm A: 114 mm
609 420-106/116	x							Press-Pull Sleeve I: 106 mm A: 116 mm G1
609 420-108/118	x							Press-Pull Sleeve I: 108 mm A: 118 mm G2
609 420-110/120	x							Press-Pull Sleeve I: 110 mm A: 120 mm G3
609 420-112/122	x							Press-Pull Sleeve I: 112 mm A: 122 mm G4
609 420-74/84	x							Press-Pull Sleeve I: 74 mm A: 84 mm G1
609 420-76/86	x							Press-Pull Sleeve I: 76 mm A: 86 mm G2
609 420-78/88	x							Press-Pull Sleeve I: 78 mm A: 88 mm G3
609 420-80/90	x							Press-Pull Sleeve I: 80 mm A: 90 mm G4
609 420-82/92	x							Press-Pull Sleeve I: 82 mm A: 92 mm
609 420-84/94	x							Press-Pull Sleeve I: 84 mm A: 94 mm
609 420-86/96	x							Press-Pull Sleeve I: 86 mm A: 96 mm
609 420-88/98	x							Press-Pull Sleeve I: 88 mm A: 98 mm
609 420-90/100	x							Press-Pull Sleeve I: 90 mm A: 100 mm G1
609 420-92/102	x							Press-Pull Sleeve I: 92 mm A: 102 mm G2
609 420-94/104	x							Press-Pull Sleeve I: 94 mm A: 104 mm G3
609 420-96/106	x							Press-Pull Sleeve I: 96 mm A: 106 mm G4
609 420-98/108	x							Press-Pull Sleeve I: 98 mm A: 108 mm
609 420/A	2x							Adapter for Step Discs
609 420/Basic								Pressing + Pulling Tube Kit II (Basic)
609 420/D16	2x							Nut M16 with Bearing
609 420/M10	x	x			x	x		Counter Nut M10
609 420/M12	x	x			x	x		Counter Nut M12
609 420/M14	x	x						Counter Nut M14
609 420/P1	x							Step Disc No. 1
609 420/P2	x							Step Disc No. 2
609 420/P3	x							Step Disc No. 3
609 420/P4	x							Step Disc No. 4
609 420/TR20K	x	x			x	x		Spindle TR 20, short with inside adapter thread M10, M12, M14
609 420/TR20L	x							Spindle TR 20, long with inside adapter thread M10, M12, M14
609 420/TR20M	x	x			x	x		Nut TR20 with Bearing
609 420/Upgrade								Pressing + Pulling Tube Kit II (Upgrade)
906 007					x	x		Special lubricant



609 390/Basic



609 400/460

UNIVERSAL RACE PULLER



WATCH DEMO HERE:

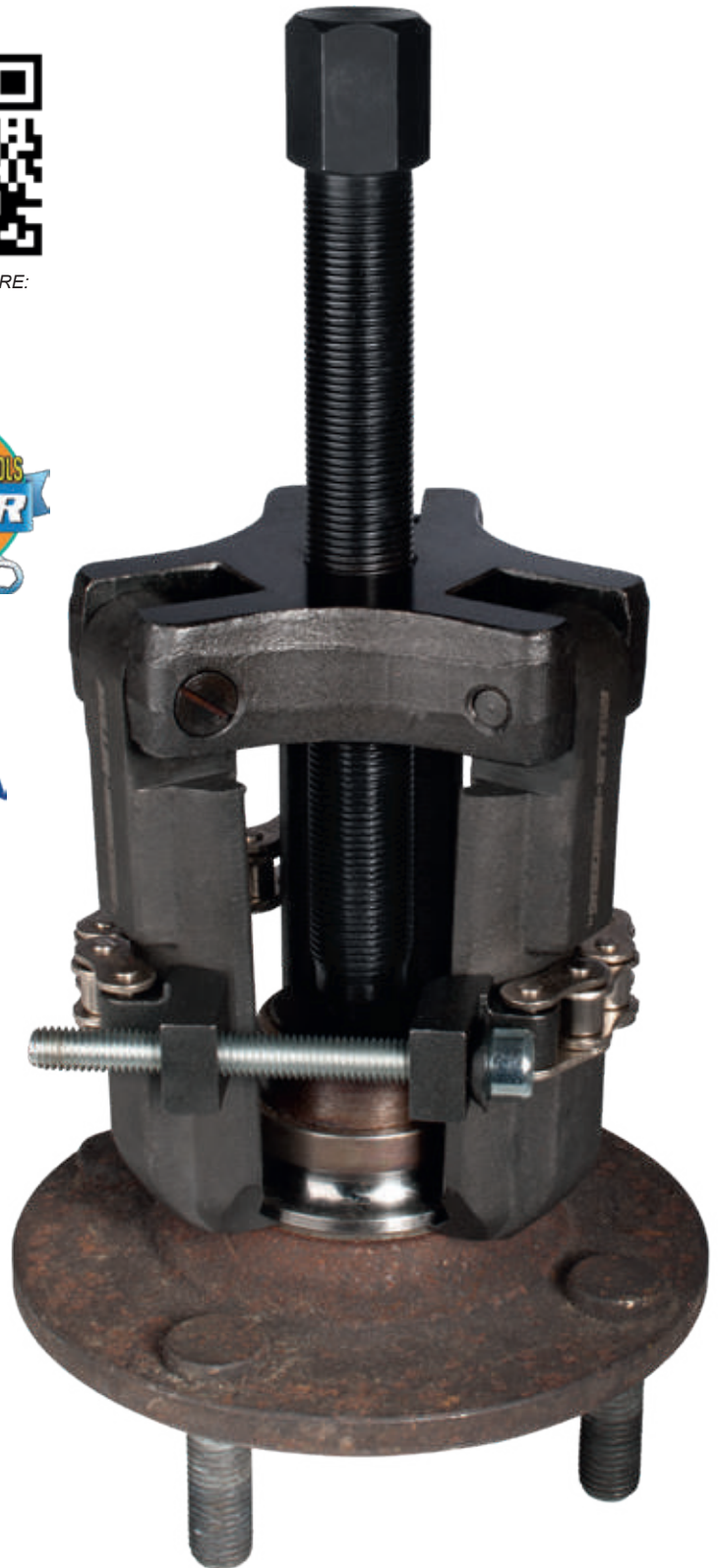

The **ONLY** race puller like it on the market.

Universal bearing ring puller with a revolutionary gripping principle. A three-legged gripper with ultra sharp edges provides equal gripping power on each side, avoiding any tilt.

Additionally, the easily adjustable clamping chain offers ideal grip and power for best efficiency.

Fits all kinds of bearings and sleeves between 40 and 60 mm.

- Ships in a sturdy plastic case
- Full firm grip based on the adjustable clamping chain
- Ultra sharp edges will clamp into the 0.5 mm radius of the ring

650 200

Universal Race Puller

U.S. Patent pending

UNI PULLER SET XS

- Unique set, currently no other like it on the market
- Provides multiple ways to remove bushings, seals, sleeves, bearings, bearing races, pressed-in studs and more.
- Includes a 2.5 LB slide hammer, two sets of jaws, internal and external puller, puller hook, pressed-in stud puller adapter, injector adaptor which fits M14 X 1.5 (most common injector size), and split collet extractors.
- Split collet extractors are made for "blind" holes.
- Slide hammer can be used 2 ways, move the handle horizontally for narrow spaces.
- Kit can be used when there is not a lot of space behind bearings.

650 500 Uni Puller Set XS

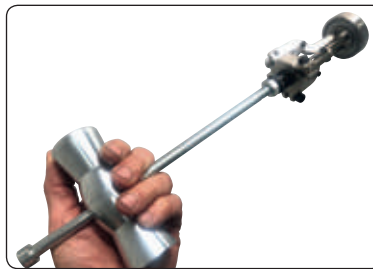

HYDRAULIC TWIN / TRIPLE LEG PULLER SYSTEM

- To be used manually.
- 8ton. ram, self gripping principle
- Combination twin / triple leg puller kit complete with ram extensions, offer a wide range of pulling options.
- Makes 2 different twin / triple leg pullers.
- Supplied in a foam inlay.

650 700 Hydraulic Twin / Triple Leg Puller System

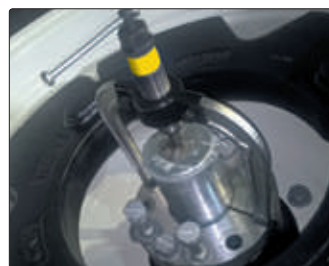

Self Gripping Principle



Technical information		
Puller Spread	Puller Reach Max	Ram Extension
min - max mm	max mm	mm
50 - 100	100	50

ALIGNMENT-WRENCH FOR MERCEDES REAR AXLE ALIGNMENT



- Universal fit for most Mercedes
- Adjust the rear axle toe without removing plastic underbody cover
- Avoids damaging plastic fasteners
- Saves time and money

512 712 Alignment-Wrench
For Mercedes rear axle alignment

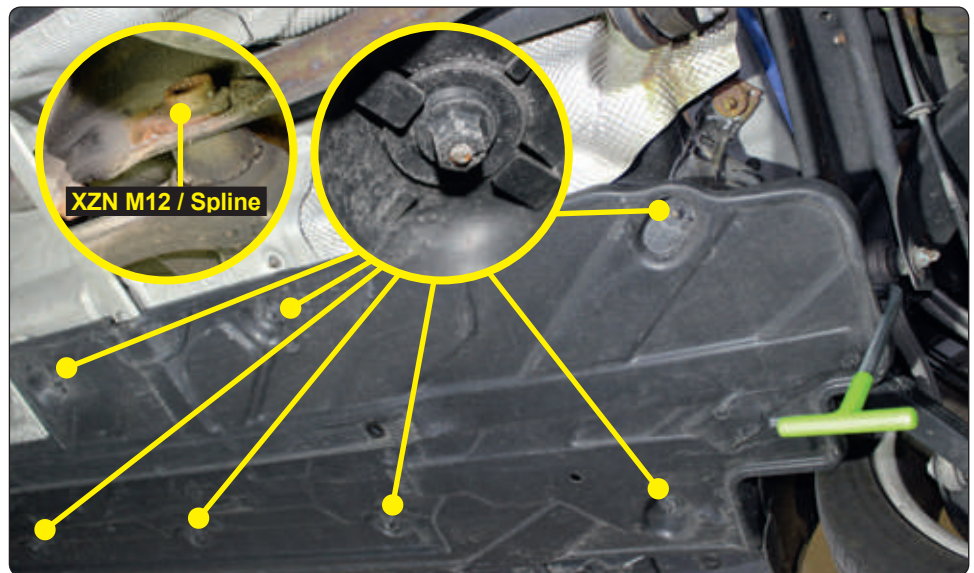

WHEEL CAMBER ADJUSTER

For exact and sensitive adjustment of the wheel camber.
Fits many cars. Perfect for VW Golf II, Golf III, Passat.

514 300/2 Wheel camber adjuster 2 pcs.



MOUNTING PUNCH

For bearings, bolts, bushings etc.

841 001 Brass mounting punch
20x300mm

841 030 Aluminium mounting
punch 30x300mm

841 001
Ø 20x300mm

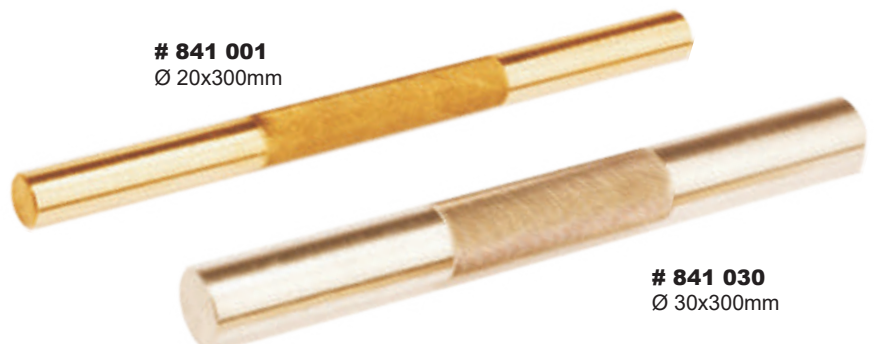

841 030
Ø 30x300mm

WHEEL WEIGHT REMOVER

Brake & Wheel



Blade-length: 160 mm

Ergonomic tool that has many uses. Can be used for removing sticky wheel weights or trim.

282 230 **Wheel Weight Remover**



WHEEL WEIGHT PLIER



- Specifically made to remove sticky wheel weights from aluminum rims.
- Thin edges grip the wheel weight without damaging the aluminum, leaving no scratches or notches in the metal.
- The pliers will never touch the wheel as the weights lean on their own tape.
- Features a spring-loaded handle.
- Rubber coated grip provides a comfortable handle.
- Wheel weights are fast and easy to remove.

282 240 **Wheel Weight Plier**



INNER RIM CLEANER



TOOL-INNOVATION 2017

The Mueller Kueps Inner Rim Cleaner is meant for the optimal cleaning of the inner wheel contact surface. It prevents corrosion related distortion of wheel bolt tightening torque and allows you to completely remove burnt in corrosion. To be used only on the inside of an aluminum rim, particularly the inner area prior to wheel balancing. Due to the porous abrasives and a cup shaped grinding plate there is minimal dust and the Velcro adhesive makes it easy to change out. It has been optimized for the latest wheel rims with an enlarged diameter of 75mm.

433 507 Inner Rim Cleaner

433 508 Replacement Discs for Inner Rim Cleaner, 3 pcs.

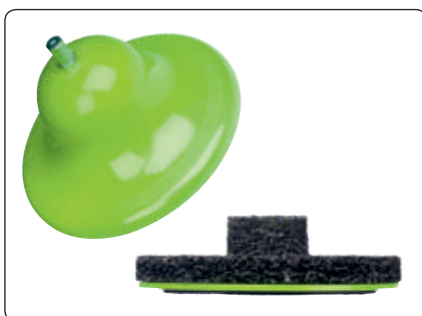

**Shipment no. 433 507:
1 basic unit + 1 disc**



**to use before
balancing**

WHEEL HUB GRINDER TYPE 1, 1/2" drive, Ø 75mm internal



Special grinder for cleaning the wheel centering device and the attachment face between WHEEL and HUB. Stubborn corrosion residue is removed quickly, easily and completely. Optimized for use with an Impact gun. Actual processing time per hub 3 - 25 seconds. Works best at lowest rpm.

433 500 Wheel hub grinder type 1, 1/2" drive, Ø 75mm internal

433 503 Spare discs, 3 pcs.



Shipment # 433 500: 1 basic unit + 1 disc



WHEEL HUB GRINDER TYPE 1



The Mueller-Kueps Wheel Hub Grinder Type 1 is meant for the optimal cleaning of the wheel and hub contact surfaces.

Burned in corrosion residue is completely removed with a quick and easy process. The porous abrasives and a cup shaped grinding plate reduce dust while a Velcro adhesive makes it easy to change out discs.

Actual processing time per hub is about 3-25 seconds depending on the thickness of corrosion.

This tool has an Outer Diameter of 160mm.

**# 433 502/M Wheel Hub Grinder Type 1
(1 holder + 1 disc) Ø 160 mm**

433 501 Spare Disc for Wheel Hub Grinder 3pcs



WATCH DEMO HERE:

WHEEL HUB GRINDER TYPE 1 - 75 MM INTERNAL



Grinding Ø 160mm



Max. speed 1500 rpm

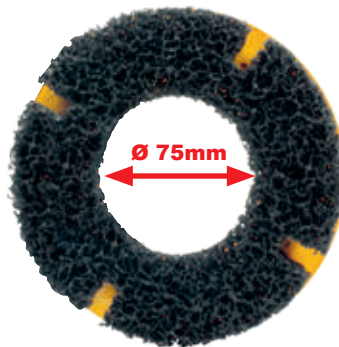

With larger internal diameter (75mm) for vehicles, e.g. BMW.



Shipment no. 433 504: 1 basic unit + 3 discs

This tool is meant for the optimal cleaning of the wheel centering device and the attachment face between wheel and hub.

Burned in corrosion residue is completely removed with a quick and easy process. The porous abrasives and a cup shaped grinding plate reduce dust while a Velcro adhesive makes it easy to change out discs.

Actual processing time per hub is about 3-25 seconds depending on the thickness of corrosion. This tool has an Outer Diameter of 160mm and an Inner Diameter of 75mm.

Specifically meant for larger internal diameter vehicles such as BMW.

433 504 Wheel hub grinder type 1, 75mm internal

433 505 Spare discs for wheel hub grinder 1, 75mm internal, 3 pcs. Also fits basic unit no. 433 502.

WHEEL HUB GRINDER TYPE 3

The Mueller-Kueps Wheel Hub Grinder Type 3 is meant for the optimal cleaning of the wheel and hub contact surfaces.

Burned in corrosion residue is completely removed with a quick and easy process. The porous abrasives and a cup shaped grinding plate reduce dust while a Velcro adhesive makes it easy to change out discs.

Actual processing time per hub is about 3-25 seconds depending on the thickness of corrosion.

This tool has an Outer Diameter of 200mm.

433 700 Wheel Hub Grinder Type 3 (1 holder + 2 disc) Ø 200 mm

433 720 Spare Disc for Wheel Hub Grinder 2pcs



ALUMINIUM WHEEL HUB GRINDER TYPE 2



Content: 1 basic unit + 5 discs Ø 40 mm and 6 discs Ø 50 mm

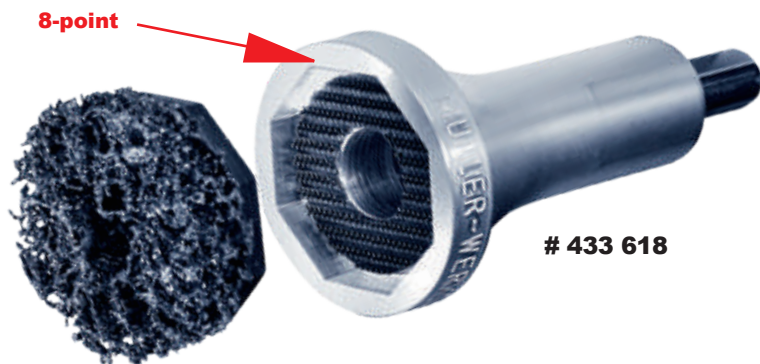

This hub grinder is meant for the optimal cleaning of the wheel rim contact surfaces.

Burned in corrosion residue is completely removed with a quick and easy process. The porous abrasives reduce dust while a Velcro adhesive makes it easy to change out discs.

Actual processing time per hub is about 3-25 seconds depending on the thickness of corrosion. It comes with 40mm and 50mm Outer Diameter discs.

433 618 Aluminium-Wheel Hub Grinder Type 2 with 11 discs

433 648 8-point spare disc small 5pcs

433 658 8-point spare disc large 5pcs

433 618/M 8-point-Alu-Wheel Hub Grinder Type 2 with 5 discs

433 918 Aluminium-Wheel Hub Grinder Trucks

433 958 8-point spare disc 5pcs

433 958/PUR 8-point spare disc rough 5pcs

VALVE CORE TOOL

- Insert the Tool into the valve stem.
- Tool will "click" when properly connected to core.
- Upon removal the tool will retain the core.
- Easily and quickly replace the core.
- For one handed operation.

437 001 **Valve Core Tool**
with valve core holder

437 001/4 **Valve Core Tool**
with valve core holder, 4 pcs.



BRAKE HEX BIT KIT

**Length:
45mm**



6mm

7mm

8mm

9mm

11mm

Universal use in narrow spaces. The hard to reach hex bolt of the brake caliper can be easily screwed due to the turnable ratchet wrench. The kit includes 6, 7, 8, 9, 11mm hex bits.

456 550/6 **Brake hex bit kit**

Example of use:
VW / AUDI, rear brake caliper.



LINE WRENCH KIT WITH JOINT



- Completely Drop-Forged
- High Quality Chrome Finish
- Both Ends with Inner Hex
- Stepped Flange Shape

457 705 Line Wrench Kit 5pcs.
8, 9, 10, 11, 12 mm

**Perfect for brake lines,
 power steering lines,
 air conditioning
 lines and hydraulic lines.**



Also separately available:

Line Wrench 13 mm	# 457 713
Line Wrench 14 mm	# 457 714
Line Wrench 15 mm	# 457 715
Line Wrench 16 mm	# 457 716
Line Wrench 17 mm	# 457 717
Line Wrench 18 mm	# 457 718
Line Wrench 19 mm	# 457 719

BRAKE LINE WRENCH 11 MM



Special brake bleeder wrench for the actuation of bleeder screws.
Saves the disassembling and reassembling of the wheels.

458 711 e.g. for VW Golf 5, Audi A3, etc.

458 811 e.g. for VW Passat, Audi A4, etc.

458 711 Brake Line Wrench 11 mm Long

458 811 Brake Line Wrench 11 mm Short

BRAKE CALIPER FILE



460 202

High quality,
ergonomic handle

460 200

Brake Caliper File with scraper on the face end,
for removal of coarse residue.

460 200 Brake Caliper File

**# 460 202 Brake Caliper thin File
for Asian imports**

NEW!

Ergonomic 2 component handle

MINI-RATCHET PIPE CUTTER



This ratchet pipe cutter is an ideal tool for professionally cutting brake pipes. Compact design and ratchet function mean it can be used directly on the vehicle including hard to reach areas. Automatic readjustment function means no need to retighten the cutting wheel during the cutting process. Handle length provides additional leverage.

462 002 Mini-ratchet pipe cutter Ø 4,75mm, 3/16"



BRAKE CALIPER BRUSH KIT



Brass bristles

Steel bristles

To remove burned in brake dust and dirt from brake calipers. Set includes 1 steel brush and 1 brass brush. Application for brass brush: Use on aluminium brake calipers. Application for steel brush: Use on steel brake calipers. Soft brass bristles ensure a proper cleaning. Length: 225mm.

467 000 Brake caliper brush kit

467 001 Brake caliper brush steel

467 002 Brake caliper brush brass



BRAKE PIPE COATING REMOVAL TOOL

Adjustable for pipe diameters: 3 - 16mm (1/8" - 5/8"). Allows protective nylon coating (seen in particular VAG and GM models) to be removed prior to flaring the brake pipe. Prevents 'bad flares' which occur when brake pipe is flared with coating, this can lead to leakage.

462 004 Brake pipe coating removal tool



Adjustable 3-16mm

BRAKE LINE STRAIGHTENER

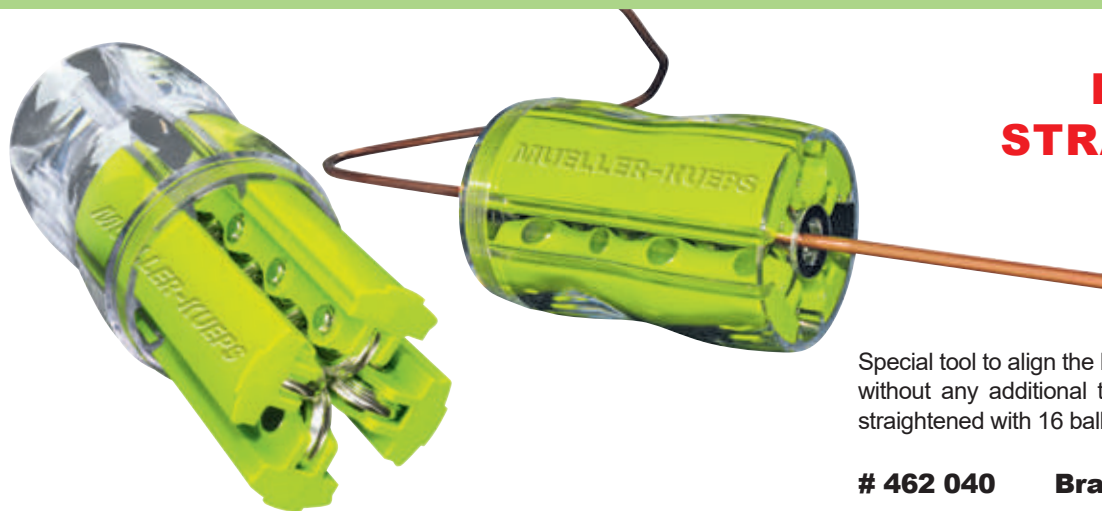

Special tool to align the brake tube lines. Easy to use without any additional tools. The brake line will be straightened with 16 ball beared precision rolls.

462 040 Brake line straightener

AIR BRAKE PISTON RESETTER

A universal use brake piston resetter which works for left and right threaded pistons. The kit includes: 2 adjustable discs, foam inlay and a 6-8 bar.

468 026 Air brake piston resetter



Adjustable Brake Piston Reset Discs

Professional reset of the rear axle brake pistons. The exact distance of the rotating disc adapts automatically to the bores of the brake piston by turning the basic unit of the disc.

- Repair almost every car with these two discs!
- Time saver

468 020/47 2-pin Adjustable Disc

468 020/48 3-pin Adjustable Discs



468 020/47
2-pin Adjustable Discs



468 020/48
3-pin Adjustable Discs



1/2" x 600mm RATCHET BREAKER BAR

Busts loose stubborn bolts. 210 degree swivel head. Can be used straight as a ratchet for narrow spaces.

512 610 1/2" x 600mm Ratchet breaker bar

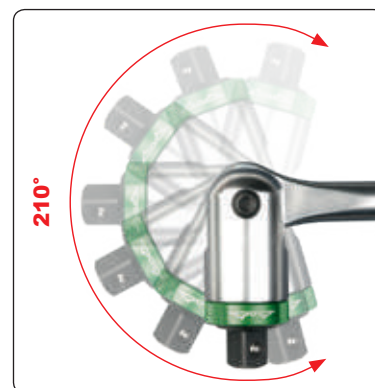

TPMS/RDKS TOOL KIT



Needed for mounting and demounting of the valve-type TPMS sensors. These tools ensure that the sensitive TPMS-sensors parts such as the hex-nut or valve core will be tightened with the proper torque, which is required by the TPMS sensor manufacturer.
6pcs T-handle with Nm-Limiter and special sockets kit.
This kit fits nearly all TPMS sensors on the market.



531 049 TPMS/RDKS Tool kit

UNI-EXTENDER

Uni-extender to loosen tight connection in hard to reach areas.

- Fits wrenches perfectly
- To loosen tight connection of hex, TX and XZN
- Reduces risk of injuries.

745 100 Uni-Extender
length: 340 mm; max. SW26 / 26 mm

745 101 Uni-Extender Type 1
length: 450mm; max. SW32 / 32 mm

745 102 Uni-Extender Type 2
length: 580 mm; max. SW46 / 46 mm

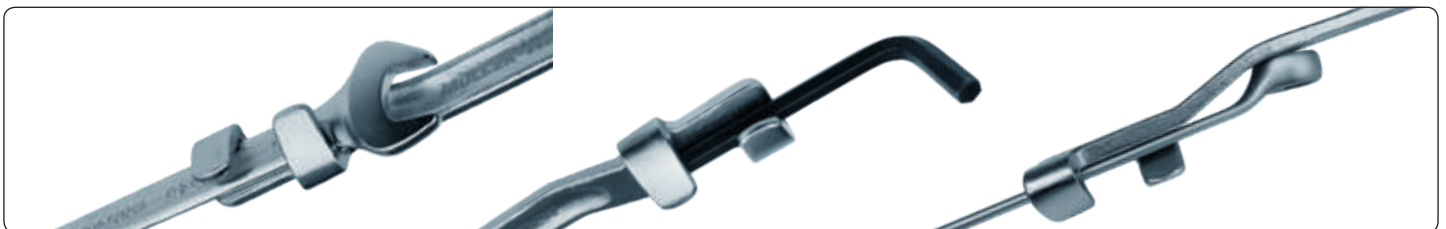

XL WHEEL MOUNTING SOCKET KIT

length: 150mm

The individual sizes are colour-coded (yellow, blue, green)

Sizes: 17, 19, 21mm

Extra long and thin walled design



High-quality, extra long, thin-walled single-piece design. Ergonomic design for removal and mounting of wheels in specialist workshops. For use with Torque Wrench! The individual sizes are colour-coded.



800 200 XL wheel mounting socket kit, 3 pcs.

UNI-HOOK-KIT

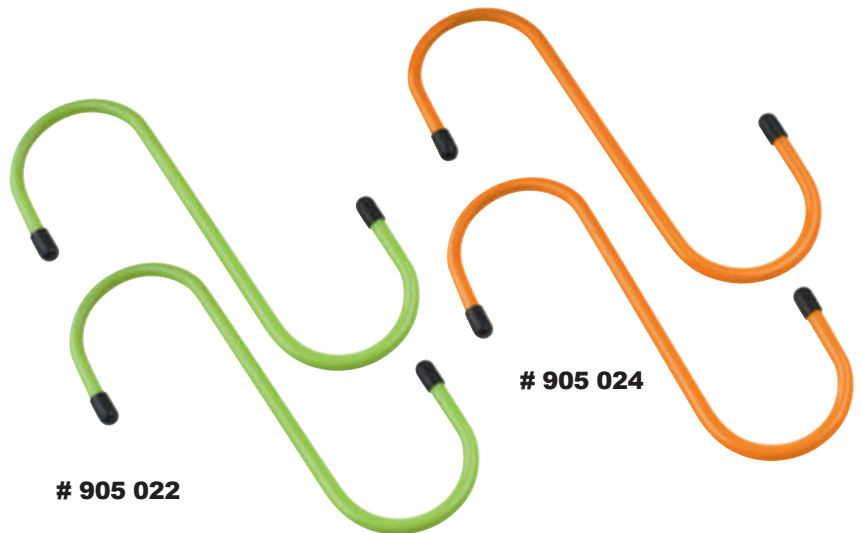
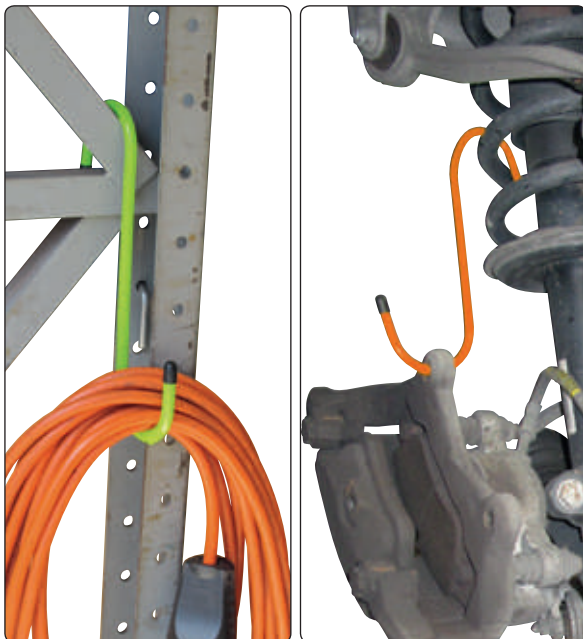

905 022

905 024

i. e. brake caliper, cords, etc.

905 022

Uni-Hook-Kit

flexible / universally adjustable; for use up to 8 LBS

905 024

Uni-Hook-Kit

rigid; for use from 8 LBS and up

Engine

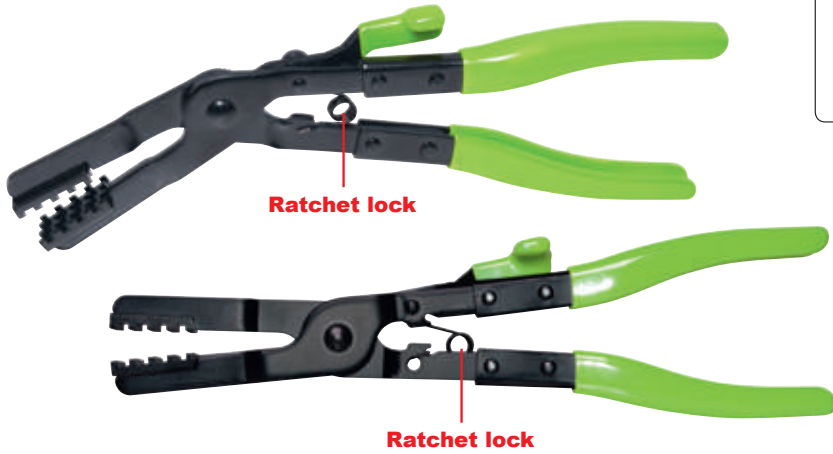

HOSE CLAMP PLIER KIT

Universal hose clamp plier kit. New head design for multi angle gripping. Ratchet lock holds the hose clamp open. Length 280mm.

500 035 2pcs hose clamp plier kit

UNIVERSAL BELT WRENCH

Universal fit for oil filter and dehydrator cartridges, 1/2" drive, max diam. 180mm / 7". Will not ruin the filter. This tool is advised to be used by Caterpillar.

551 005 Universal Belt Wrench



SPARK AND GLOW PLUG STARTER

Flexible rubber tool.



For hard to reach spark- and glowplugs.



Useful tool to install the first pitch of common rail glow plugs. Fits spark plugs as well.

651 001 Spark and Glow Plug Starter

GLOW PLUG DRILL KIT

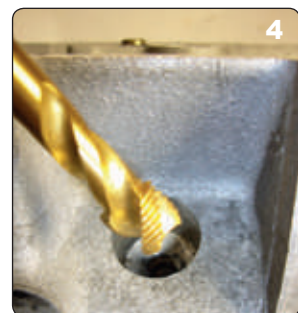

optional:
600 121
Small slide hammer



Removing broken glow plugs can become a hassle when not done with the right tools. Mueller-Kueps aims to make your life easier by providing you with a kit to remove these broken glow plugs. 5 easy steps make this a safe and effective way to achieve your task.

Included in this kit are sockets, a 3-fluted step drill, 2 sizes of thread tappers, an extractor and a straightforward picture manual.

This set works best when used in conjunction with the Small Slide Hammer # 600 121.

- # 600 240 **Glow Plug Drill kit M10x1**
- # 600 242 **Glow Plug Drill kit M12x1.25**
- # 600 245 **Glow Plug Drill kit M10x1.25**
- # 600 248 **Glow Plug Drill kit M8x1**

SMALL SLIDE HAMMER



The Small Slide Hammer features a 2.5 LB weight and can be used in two ways. Use it with the handle vertically for regular pull. Move the handle horizontally to be able to use the slide hammer in narrow areas while still providing maximum pull. This makes the tool one of the more versatile small slide hammers on the market.

- # 600 121 **Small slide hammer**

UNI INJECTOR PULLER KIT

Universal kit for diesel injectors. Fits Bosch, Delphi, Denso, and Siemens. Will work in most cases without removing the electric plug.

600 130 Uni Injector puller kit



Curved hook centers the impact of the slide hammer. To be used for dismantling injectors.

600 120-1 Injector Puller Adaptor



Clean glow plug hole to prepare for installation of new glow plug. Includes 5 steel wire brushes for the M8 and M10. 3 brushes to clean the glow plug element hole and 2 brushes to clean the shaft.

600 260 5 pcs glow plug brush kit

COMPLETE KIT FOR GLOW PLUGS ELECTRODE EXTRACTION

Set of tools for the extraction of the glow plug tip in the event of breakage or seizure inside the seat, which is otherwise impossible to remove.

Suitable for glow plugs with thread:

- M10x1
- M10x1.25
- M9x1
- M8x1.

The set includes all the tools needed to safely remove the terminal part of the glow plug electrode without damaging the cylinder head. Our procedure saves you a considerable amount of time versus the alternative of having to disassemble the head.

600 300 Complete kit for glow plugs electrode extraction



SPOT WELDING DRILL BITS

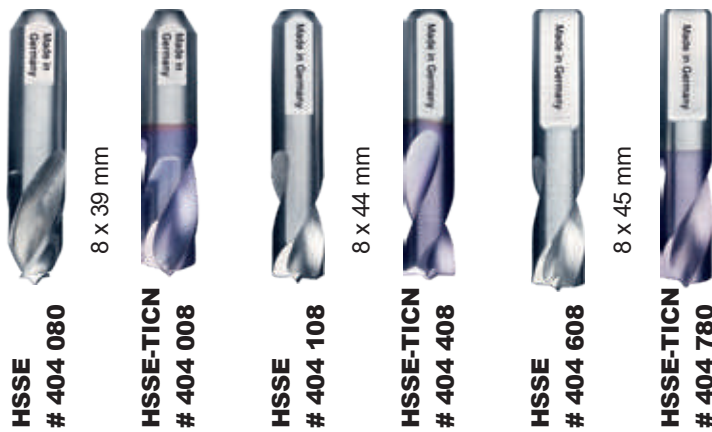

High quality standard HSSE (High Speed Steel Cobalt Alloyed)

Best standard Spotweld Drill available

Double coated > HSSE-TICN (HSSE-Titanium Carbon Nitride)

PVD Titanium coating with a Carbon Nitride finish. Highest cutting speed. Used for interrupted cuts and has a long lifetime for best profitability.

Cutting Tools



HSSE
244 060
244 008
244 010

6 x 70 ; 8 x 80 ; 10 x 90 mm

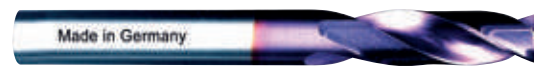

HSSE-TICN
244 806
244 808
244 210

All Drill Bits are:



CARBIDE SPOT WELD DRILL BIT

Made especially for removing spot welds on extremely hard steel materials, such as BTR, BOR.

Use with cordless or air drill. No turning inside drill chuck, due to the 3 flat gripping areas.



222 051

Carbide spot weld drill bit 3-edged 8,0 x 50 mm



222 308

Carbide Spot Weld drill bit 8,0 x 44 mm. Fits the 401 001.

SPOT WELD DRILL



The Tool to use for drilling High Strength Steel!

Operates at 1200rpm or less. Drill bits will last longer.

Use for removing spot welds on all flanges. Comes with removable "G-clamp".

Adjustable depth to ensure there is no drilling in second panel.

To extend the life of the drill bit, use the center punch and the special cutting oil.

401 001

Spot weld drill

5-PACK SPOT WELD DRILL BITS



HSSE-Titanium Carbon Nitride!

244 805

5-pack Spot Welding Drill Bits: 2 x 6 mm, 3 x 8 mm

Auto Body / Consumables

FINISH PANEL DETACHEMENT

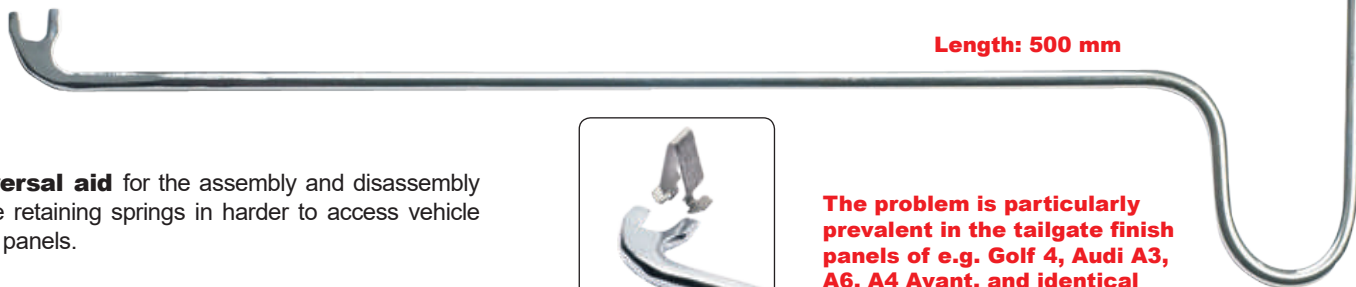

Length: 500 mm

Universal aid for the assembly and disassembly of the retaining springs in harder to access vehicle finish panels.

267 500 Finish panel detachment



The problem is particularly prevalent in the tailgate finish panels of e.g. Golf 4, Audi A3, A6, A4 Avant, and identical group vehicles.

CARBIDE SCRAPER KIT



MUELLER's gasket; corrosion and carbon scraper

- Double edged blade
- Extremely durable due to high quality carbide inserts
- Works as pull or push tool
- Ergonomic hand grip
- Removes paint and glue in hard to reach areas
- Removes burned in corrosion on brakes
- Carbon on exhaust manifold etc...

268 220 Carbide Scraper kit



32mm
1 1/4"

16mm
5/8"

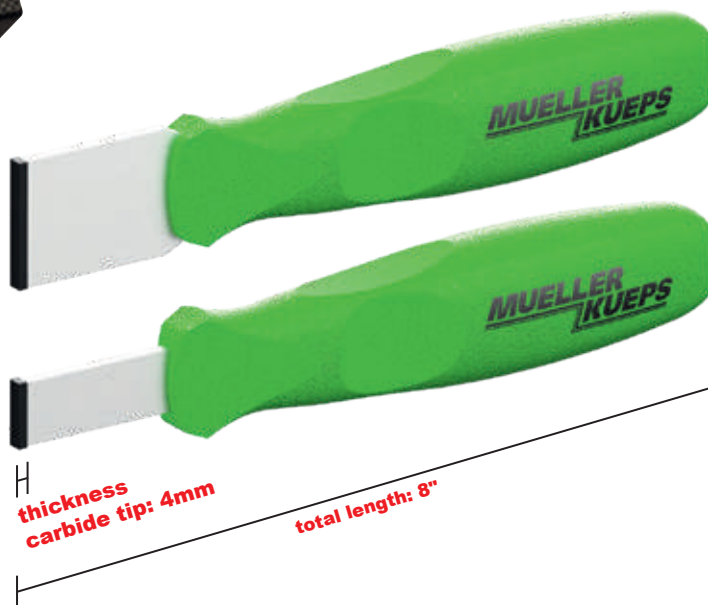

thickness
carbide tip: 4mm

total length: 8"

XL CARBIDE SCRAPER KIT

Mueller's gasket; corrosion and carbon scraper

- Double edged blade
- Extremely durable due to high quality carbide inserts
- Works as a push or pull tool
- Ergonomic hand grip
- Removes burned in corrosion on brakes, carbon on exhaust manifold etc.
- Total length of 11 in.

268 320 XL Carbide Scraper Kit



CHISEL SCRAPER KIT



2-component handles with hammer head

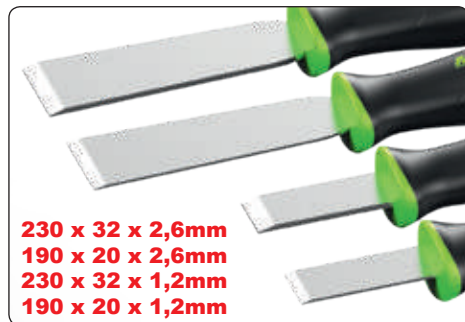

230 x 32 x 2,6mm
190 x 20 x 2,6mm
230 x 32 x 1,2mm
190 x 20 x 1,2mm

Stainless steel blade through handle, easy to re-sharpen, 2-component handles, hammer head, 4pc kit with 2 lengths + 2 thickness. Universal daily use.

268 400 Chisel scraper kit, 4 pcs.

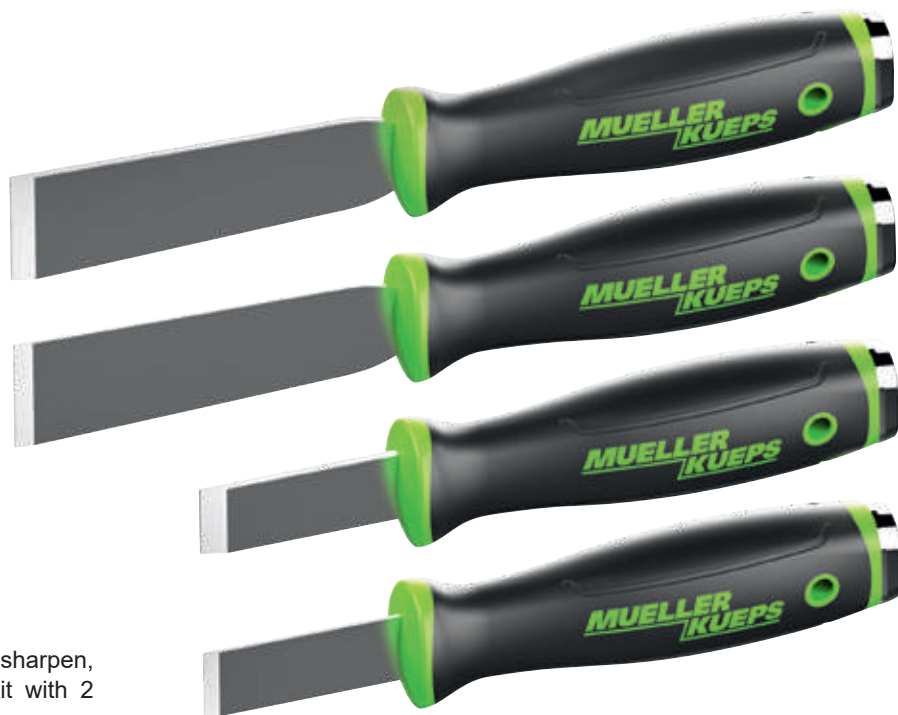

ANGLED CHISEL SCRAPER

The stainless steel blade goes through the handle. Tool is easy to resharpen and has a 2 component handle with hammer head. Features a 30° bend. Universal daily use. 230 x 32 x 2,6 mm

268 405 Angled Chisel Scraper

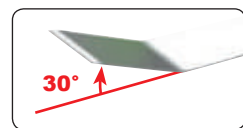

QUICK-LOCK RAZOR SCRAPER



New design of razor scraper which has a quick-lock safety release mechanism. Non slip, 2 component handle. Comes with 5 steel and 5 plastic blades.
Length: 210 mm. Blade: 39 mm.

268 420 Quick-Lock Razor Scraper

- # 268 421 Replacement Blade Plastic, 10 pcs.
- # 268 421/10 Replacement Blade Plastic, 10 x 10 pack
- # 268 421/100 Replacement Blade Plastic, 100x 10 pack
- # 268 422 Replacement Blade Stainless Steel, 10 pcs.
- # 268 422/10 Replacement Blade Stainless Steel, 10 x 10 pack
- # 268 422/100 Replacement Blade Stainless Steel, 100 x 10 pack



FLEXY DOLLY SET

Specifically made for repair work on car bodies made of steel, including high-tensile, super high-strength, extra thin sheets as well as aluminum bodies. Straightens the sheet without stretching or shrinking.

272 217 Flexy dolly set in case, 7 pcs.



272 222/1

272 222/2

272 222/3

272 222/4

272 222/5

272 222/6

272 222/7

BUMPING KIT

Total length: 700 mm
Spoon width: 60 mm

Total length: 180 mm
Rounded end Ø: 70 mm
Straight halfrounded end: 60 x 20 mm

Total length: 280 mm
Straightener width: 100 mm

Bumping kit 3 pcs.
Includes bumping spoon, round anvil, edge straightener.

272 333 Bumping kit, 3 pcs.



UNIVERSAL PANEL BEATING KIT



Brand new universal panel beating kit multiple beat inserts of different design. 2 different working depths. All parts are interchangeable. Absolutely universal use as a normal beating tool (knurled handle), or with the DUO-Sliding hammer.

272 412 Universal panel beating kit

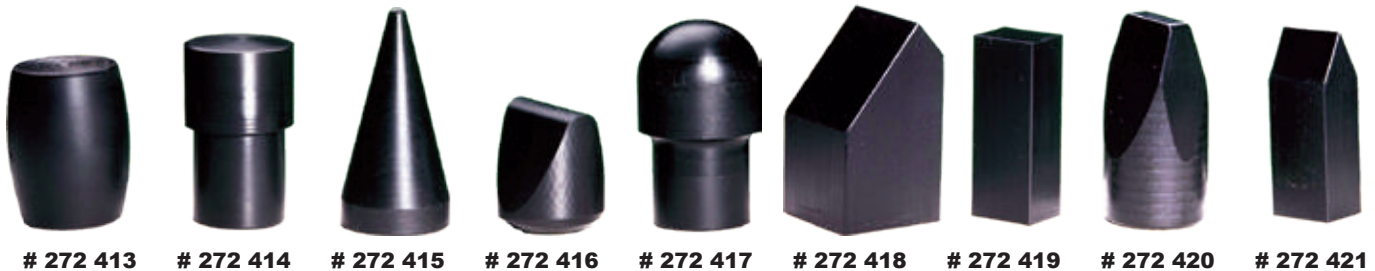
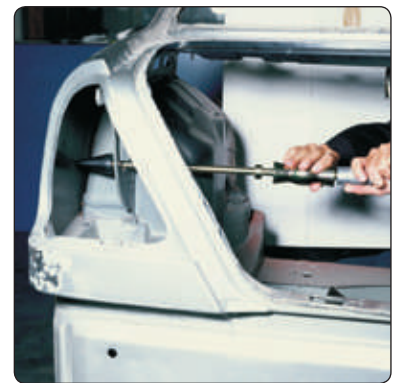

272 413 # 272 414 # 272 415 # 272 416 # 272 417 # 272 418 # 272 419 # 272 420 # 272 421

REMOVAL WEDGE 500mm



Length: 500 mm

For damage free removal of door covers and trims. Will not scratch plastic or damage paint.

277 003 Removal wedge 500mm



COMBI WEDGE



Width: 30 mm
Length: 200 mm

Combination Tool:
Ideal for door panels, headliners, dash panels, vehicle trim, etc.

277 004 Combi Wedge
277 004-10 Combi Wedge, 10 pack



COMBI WEDGE AND UNIVERSAL HOOK



Combi Wedge
Combined universal tool. Perfect for a variety of panel clips and molding removal.

Universal Hook
An ideal tool for working on door molding and a variety of other seals.

277 047 Combi Wedge and Universal Hook



PLASTIC CLIP PLIERS / FUSE PULLER



High quality, polished stainless steel pliers for removing plastic clips and fuses. Innovative design provides comfortable fit in the hand. Universal use. Length 180 mm.

- # 277 007 **Plastic Clip Pliers / Fuse Puller**
- # 277 007-10 **Plastic Clip Pliers / Fuse Puller, 10 pack**



CLIP LIFTER



5 mm

For plastic fasteners, plastic clips, upholstery or door panels.

Length: 175 mm, width: 15 mm.

- # 277 008 **Clip Lifter**
- # 277 008-10 **Clip Lifter, 10 pack**



5-PIECE CLIP LIFTER SET



For plastic fasteners, plastic clips, upholstery or door panels.

277 015 5-piece Clip Lifter Set



XL-CLIP LIFTER KIT

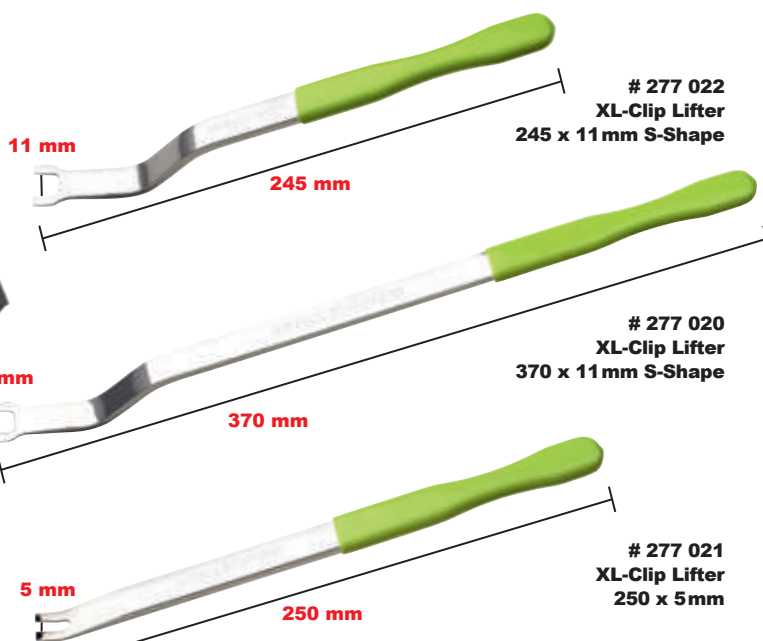

3 piece XL Clip Lifter set for all kinds of plastic fasteners, plastic clips, upholstery or door panels. Different sizes, lengths and shapes to meet all your lifting needs. Thin wedged tip for easy access.

277 023 XL-Clip Lifter Kit 3pcs

ADJUSTING TOOL FOR SPRAYING NOZZLE

For adjusting the spraying nozzle.
The extended telescop shows the direction.
Can be used as magnet pick up tool.



**Telescopic magnetic pick up,
650mm**

**# 350 004 Adjusting tool
for spraying nozzle**

MULTI FUNCTION MICRO TOOL KIT

Picks and spoons that are ideal for O-rings,
spring rings, seals, connectors etc.

**# 604 230 Multi function micro
tool kit, 3 pcs.**



FLEXIBLE MAGNETIC PICK UP TOOL

This small flexible magnet can be used to pick up
metal objects up to 300 gr. / 1/2 LB.

Overall length is 400mm.

- # 702 270 Flexible Magnetic
Pick Up Tool, green**
- # 702 271 orange Flexible Magnetic
Pick Up Tool, orange**
- # 702 273 red Flexible Magnetic
Pick Up Tool, red**

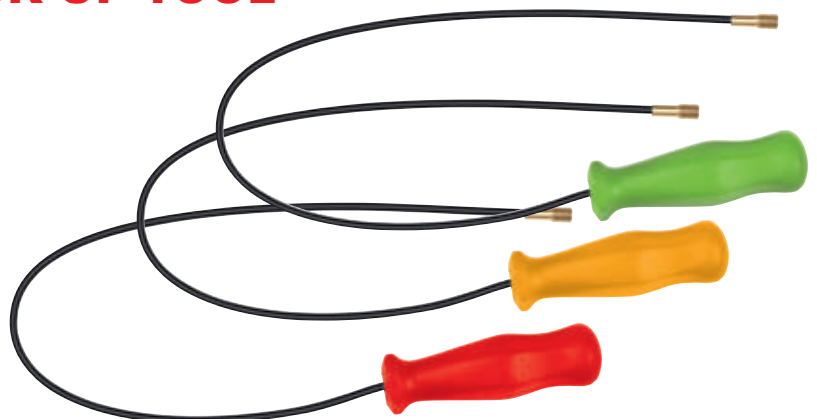

DEF / AD-BLUE 4-IN-1 REFRACTOMETER

The kit includes:

- Refractometer.
- Soft cloth.
- Long-neck dropper.
- Screw driver (for calibration adjustment).
- Pointer.

Refractometer for testing the quality of Ad-Blue, radiator coolant, windshield washerfluid and battery acid tester. 4 scales in one tester!

**# 727 090 DEF / AD-Blue
4-in-1 Refractometer**

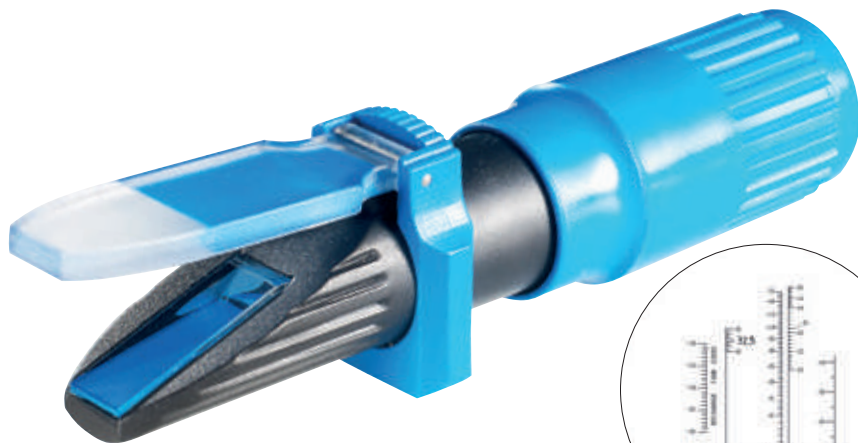

LED-DUO LAMP / WIRELESS CHARGER

MUELLER-KUEPS technical information			
	Work light		Flashlight
	100%	40%	100%
Light output	500lm	250lm	135lm
Run time	2,5h	5h	5h
Beam distance	27m	19m	38m
Peak Beam Intensity	187cd	92cd	375cd
Impact resistance	2 Meter		
Battery	18.650 (3.7V / 2.600 mAh)		

600 LUMEN
Li 2.6 Ah

Universal LED-lamp with hook, magnet and wireless charger.
Run time: 2.5 - 5h

**# 904 996 LED-DUO Lamp /
Wireless Charger**

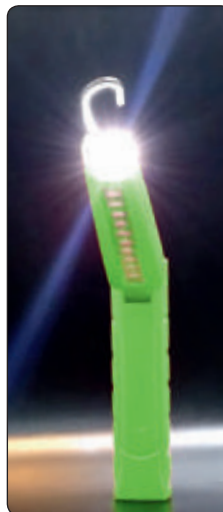

Universal Tools

THE MUELLER COLOR CODED KIT

558 001

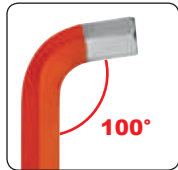

558 100



- find your tools faster through individual colour codes
- 100° bend protects your knuckles.
- works better in narrow access areas, based on reduced shank-length
- Made in Germany

558 001 **HEX color coded kit 100°**

558 100 **TORX color coded kit 100°**



COMBINATION WRENCH KIT

Extra short and handy 10 pcs. combination wrench kit 10 - 19 mm. Use for hard to reach areas such as engine, doors, electric, dashboard, radio etc.

711 100 **Combination Wrench Kit**



**no sharp edges
ergonomic design
new open end design
new sizes 16 + 18mm**



UNI-ADAPTER KIT

4 different sizes in 2 adaptors!

Changeable adaptors.

From - 1/4" to 3/8" and 3/8" to 1/4"

- 3/8" to 1/2" and 1/2" to 3/8"

Saves time and space.

800 610 Uni-Adapter kit, 2 pcs.



POLYGON IMPACT JOINT KIT

A no pin, impact adaptor set which includes 1/4", 3/8" and 1/2" adaptors. This set has a ball with flats, instead of a pin in order to maximize torque transfer. It also reduces the chances of breaking. The pieces work as both a joint and straight connector.



810 203 Polygon Impact Joint Kit

DUO DRIVE XZN 12-POINT SOCKET KIT

DUO DRIVE



— **Sizes:**
M12, M14, M16, M18
Length: 75 mm

— **Drive: 1/2" + 24 mm**

— **Length: 40 mm**

Sockets are available separately.
Ask for details.

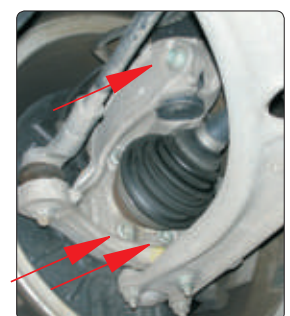
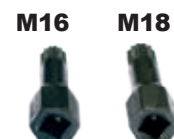

The **DUO DRIVE** sockets are triple square drive tools that are drop-forged, durable and can be used with 1/2" or 3/4" Impact tools.

DUO DRIVE sockets are especially effective on thread lock treated suspension spindle bolts.

810 808 Duo Drive XZN Socket Kit Impact 8 pcs.



KNEELING PAD

Professional workshop equipment. No need to use old cartons etc. Water, oil and gasoline resistant. Protect yourself while working. 3-layer soft material. Can be used for seat protection as well.

- works on any surface
- chemical resistant
- extremely durable
- stores easily

905 000/3 **Kneeling Pad, 3 pcs.**
480 x 36 x 320 mm

905 001 **Mechanic mat, 1pc.**
1150 x 36 x 550 mm

**Resistant to UV, oil, gas,
water and numerous other chemicals.**

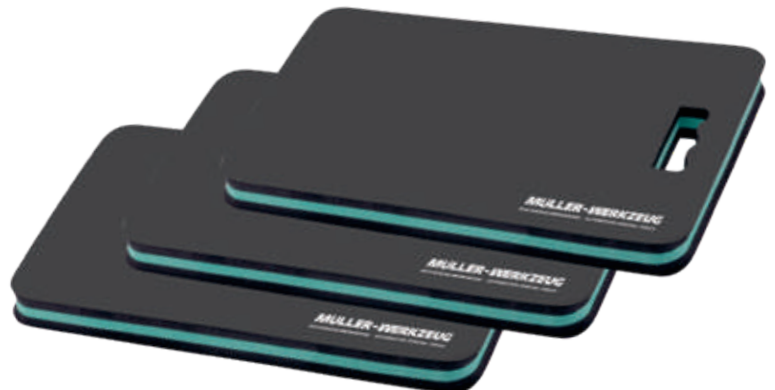

MAGNETIC PARTS BOWL



905 007/orange



905 007/neon



905 007/darkblue



905 007/gray



905 007/darkblue
Magnetic Parts Bowl, 2 pcs., darkblue

905 007/gray
Magnetic Parts Bowl, 2 pcs., gray

905 007/neon
Magnetic Parts Bowl, 2 pcs., neon

905 007/orange
Magnetic Parts Bowl, 2 pcs., orange

HEAVY DUTY SCISSORS

Mueller heavy duty scissors are ideal for leather, cloth, plastic, rubber, cardboard, gasket material, rope, wire and other materials. Both types have blades with micro teeth.

- # 905 070 **Mueller heavy duty scissor with cable cutter**
- # 905 080 **Mueller heavy duty scissor**



EPOXY PUTTY

2in1 EpoxySteel

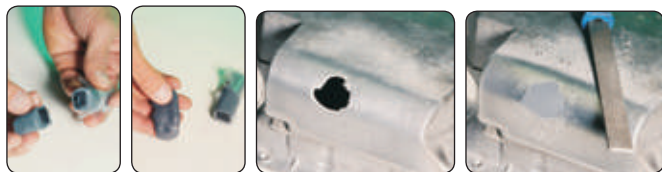

2-component epoxy putty. Easy to use. Can be reshaped after some minutes of hardening. Original EpoxySteel can be drilled, filed, milled, painted etc. Permanent heat resistant 260°. Peak temperature 290°.

- # 906 002/1 **Epoxy putty 50g**

CV JOINT GREASE



Greasing the CV joint is a difficult task due to the rigid rubber boot and hard to access area.

Because of this, it usually ends up being quite messy. With a high quality MoS2 grease and the unique Mueller cartridge this job will no longer be difficult. In a flash you will have the CV joint professionally greased by industry standard so that it can run for a long time. For a quick and clean grease job.

- # 906 033 **CV Joint Grease**

HIGH PERFORMANCE AIR HAMMER "VIBRO-IMPACT" SYSTEM

Power Tools



EQ-290 206



WATCH DEMO HERE:



290 210



290 220



290 230



290 241



"VIBRO-IMPACT" System-tool to loosen tight connections. The high performance air hammer helps to disassemble e. g. conical seat connections, wheel bearings, bushes, rusted screw connections.

EQ-290 206 High Performance Air Hammer "VIBRO-IMPACT" System

1/2" XS IMPACT WRENCH ULTRA SHORT



3-step power control



109 mm
Very low construction-height

Made for hard to reach areas

High Power:
max. 677Nm
500 ft-lb

Variable speed trigger

One hand switch

WE SET THE STANDARD
FOR **TORQUE!**

Ultra short, Extra strong!

Very strong Impact Wrench with new design. Ergonomic handle. Variable speed trigger. One hand switch. 3-speed control. Forward & reverse control can be switched to left or right handed. Aluminum/magnesium housing. Extremely powerful.

EQ-294 112 1/2" XS Impact Wrench, Ultra Short

1/2" XS-STUBBY IMPACT SOCKET KIT



Ideal to access hard to reach areas based on the ultra short construction.

Drive 1/2". 15 pcs. Delivery on rail.

810 700 1/2" XS-Stubby Impact socket kit
10-24mm on rail

extra short
28 mm



All parts separately available
(see your dealer).

Equipment

GARAGE SERVICE CART

Garage Service Cart with high load capacity. Comes with ball bearing swivel casters and locking feature.

EQ-370 Garage Service Cart

TOP
max. 300 LBs

max. 100 LBs

max. 100 LBs



PRESS AND PULL SLEEVE KIT IN GARAGE SERVICE CART

Ideal storage
Middle and bottom shelf
to store parts

Universal tool set for extracting and mounting: silent bearings, hydraulic bearings, bearing bushes, ball bearings, shaft seals, rubber bearings etc. Fully universal application. Ideal for different vehicles.

Garage service cart with high load capacity. Top shelf max. 300 Lbs. Middle and bottom shelf max. 100 Lbs. Swivel casters with ball bearings.

Inlay for press and pull sleeve kit for the ideal storage. All sleeves are clearly arranged and easy to find. Inlay fits on all three shelves of garage service cart.

EQ-371 Press and pull sleeve kit in Garage service cart



Merchandising

MEN'S OKAPI KNIT JACKET

- # 1817-995-3-M Size: M
- # 18117-995-4-L/G Size: L
- # 18117-995-5-XL/TG Size: XL
- # 18117-995-6-2XL Size: XXL



USA Sticker

Size: 6" x 2"
905 014/USA



Canada Sticker

Size: 6" x 2"
905 014/CAN



USA Magnet sign

Size: 4.76" x 1.63"
905 015/USA



T-Shirt

- # 905 010/S Size: S
- # 905 010/M Size: M
- # 905 010/L Size: L
- # 905 010/XL Size: XL
- # 905 010/XXL Size: XXL

Merchandising



MUELLER-KUEPS Baseball-Cap
M906 017



MUELLER-KUEPS Cooking Knife
made in Germany
906 015



MUELLER-KUEPS Beer Mug
made in Germany
M906 016



MUELLER-KUEPS Toolbag
M906 030
Size: 20" x 8.5"
Inside length: 17"



MUELLER-KUEPS Bag
EQ-114/K
Size: 12" x 8.5" x 2.5"

We innovate tools!

AWESOME METAL *Special*



WATCH DEMO HERE:

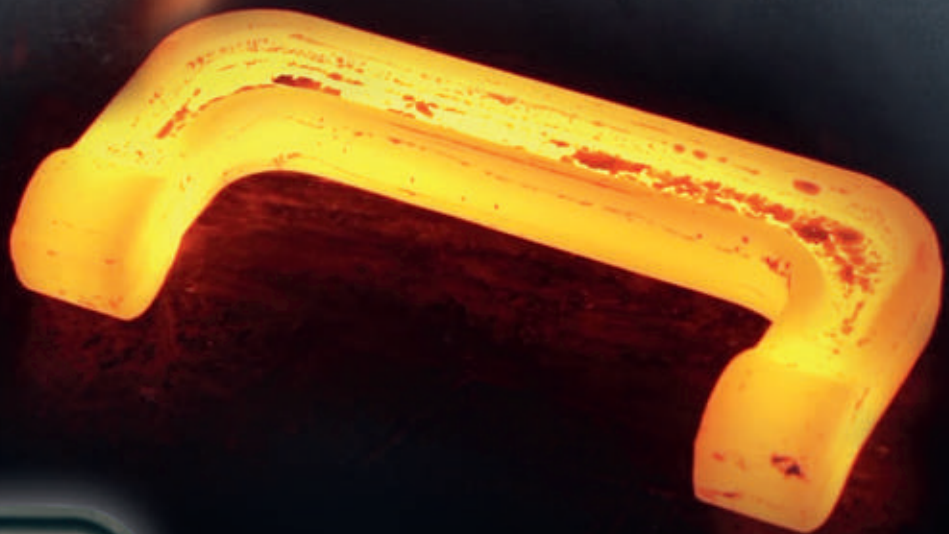

MUELLER-KUEPS LP

2220 Northmont Parkway #250
Duluth, GA 30096

Phone: +1 770 349 6331
Fax: +1 678 417 6273

info@mueller-kueps.com
www.mueller-kueps.com



MÜLLER-WERKZEUG Benelux

Toepadweg 4
NL-5301 KA Zaltbommel

Phone: +31 (0)418 / 68 03 43
Fax: +31 (0)418 / 68 03 44

info@mueller-werkzeug.nl
www.mueller-werkzeug.nl



MÜLLER-WERKZEUG GmbH & Co KG

Flurstraße 13
D-96215 Lichtenfels

Telefon: +49 (0) 95 71 / 168 87-0
Fax: +49 (0) 95 71 / 168 87-99

info@mueller-werkzeug.de
www.mueller-werkzeug.de